

A-Series Sidewall Stairs

AWT8544 and AWT8644

Assembly Instructions

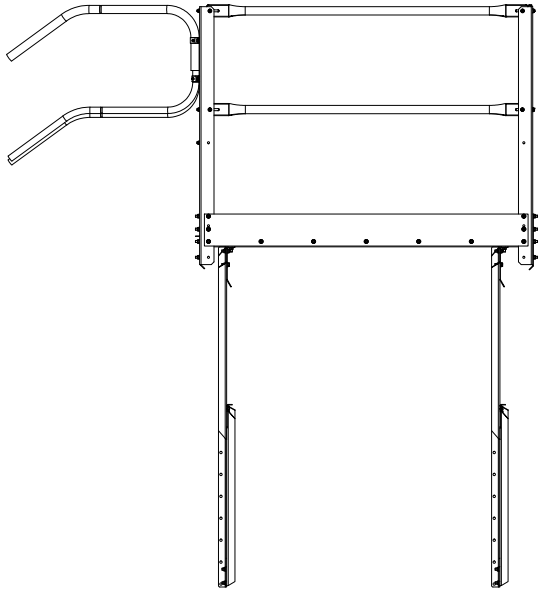
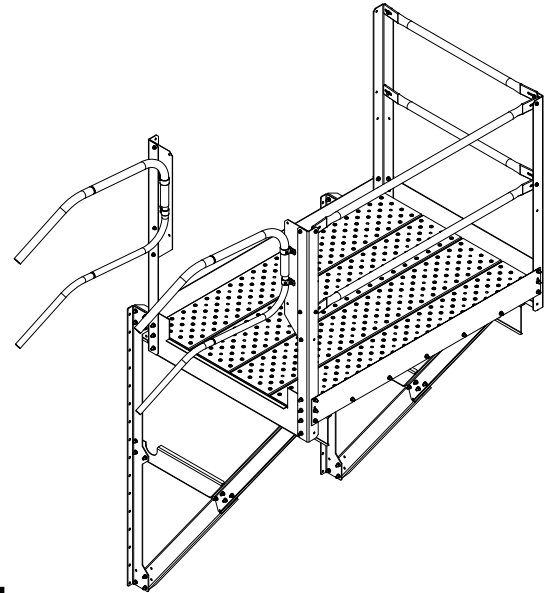

Greene Galvanized Stairs

Parts List

AS-40013

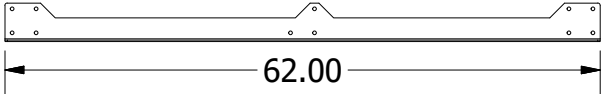

AS-40021

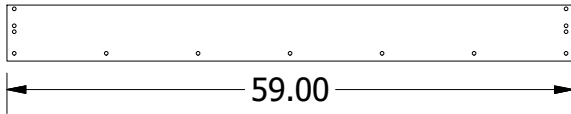

AS-40014

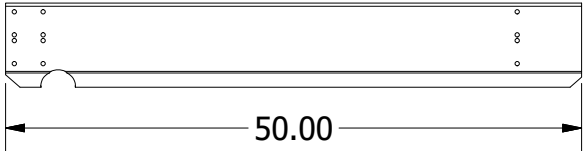

AS-40020

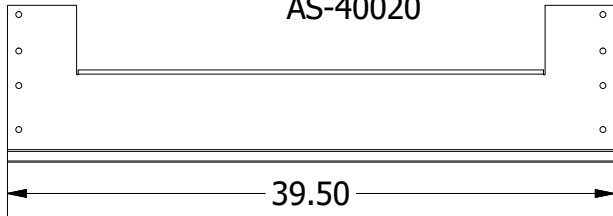

AS-40016

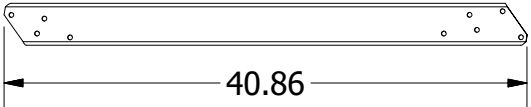

AS-40019

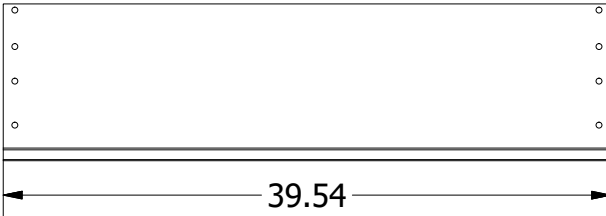

AS-40015

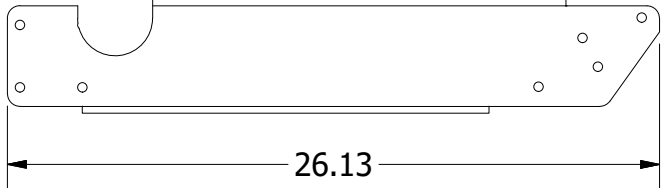

AS-40010

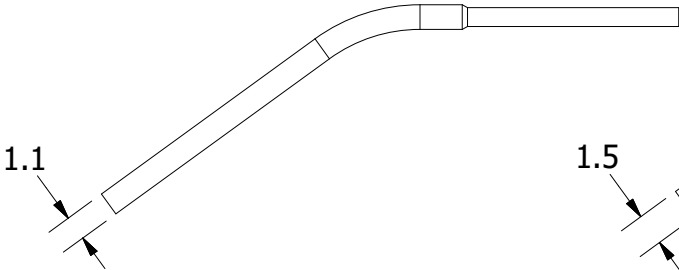

AS-40009

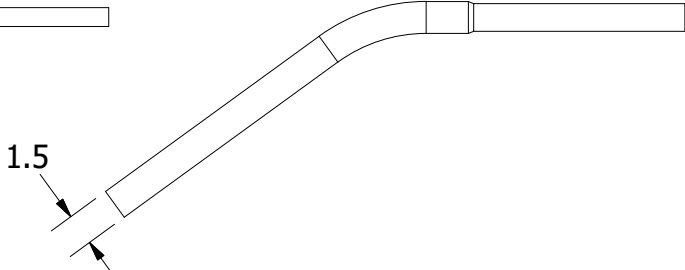

AS-40017

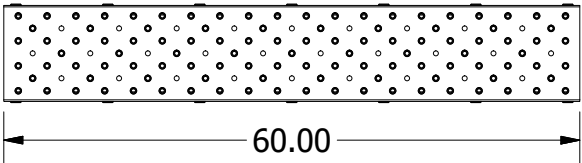

AS-40018

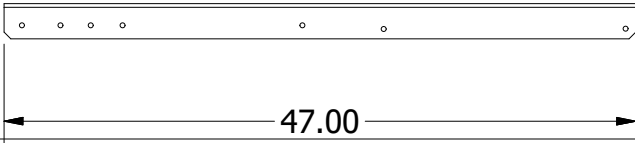

Parts List Continued

AS-40011

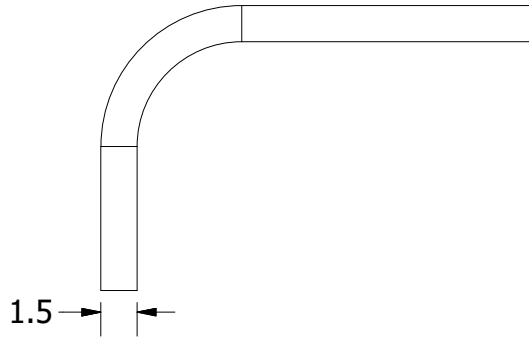

AS-40030

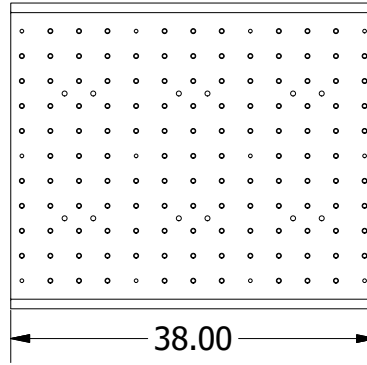

AS-40036

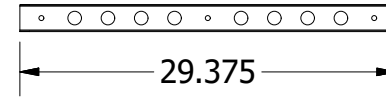

HRC1500

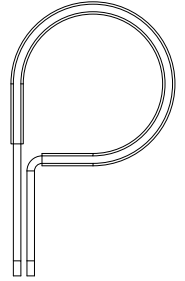

AS-40012

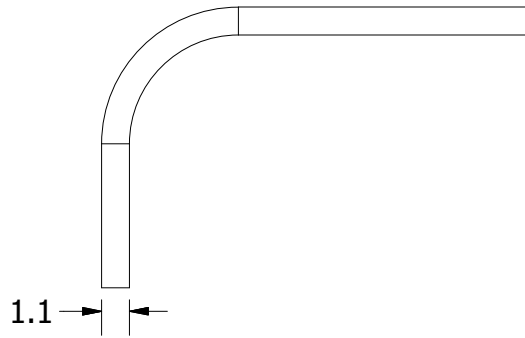

TRS1505900

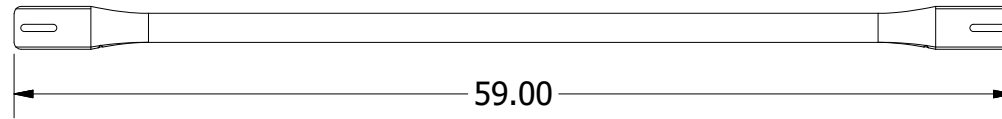

HRC1000

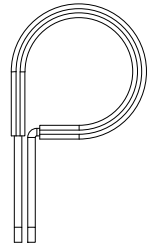

TRS1504000

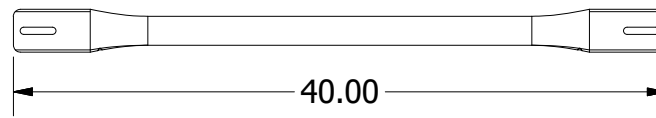

AS-40031

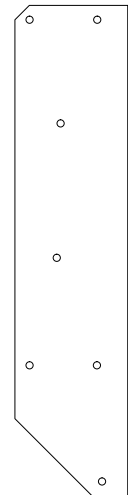

Floor Screw

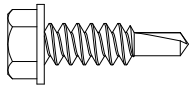

3/8-16x1SFB

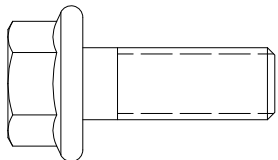

3/8-16SFN

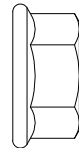

5/16-18x3/4FB

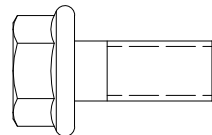

5/16-18SFN

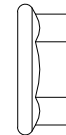

Parts List Continued

AWT8544 End Platform

PARTS LIST AWT8544		
PART NUMBER	DESCRIPTION	QTY
AS-40013	Bracket, Wall, Platform 44" ring	2
AS-40014	Crossbar, Platform	2
AS-40016	Channel, Kneebrace, Platform	4
AS-40015	Bracket, Tiebrace, Platform	2
3/8-16x1SFB	3/8"-16 x 1" Flange Bolt	125
3/8-16SFN	3/8"-16 Whiz Lock Nut	125
AS-40017	Plank, Tread, 10x60x14ga	4
AS-40018	Angle, Post, Flared	4
AS-40021	Plate, Kickboard, Side	2
AS-40020	Plate, Kickboard, Entry	1
AS-40019	Plate, Kickboard, End	1
5/16-18x3/4FB	5/16"-18 x 13/4" Flange Bolt	18
5/16-18SFN	5/16"-18 Whiz Lock Nut	18
AS-40010	1 in Railing, Rest Landing Swivel Elbow	2
AS-40009	1.5 Railing, Rest Landing Swivel Elbow	2
AS-40011	1.5 Railing End 90deg	2
AS-40012	1 in Railing End 90deg	2
HRC1500	1.5" Handrail Clamp	2
HRC1000	1" Handrail Clamp	2
Floor Screw	Self-Tapping Screw	8
AS-40030	Tread, Landing Skin	1
AS-40036	Channel Landing Support	4
AS-40031	Handrail Post Bracket	2
TRS1505900	59" Smashed Handrail 1.5" Diameter	4
TRS1504000	40" Smashed Handrail 1.5" Diameter	2

AWT8644 Through Platform

PARTS LIST AWT8644		
PART NUMBER	DESCRIPTION	QTY
AS-40013	Bracket, Wall, Platform 44" ring	2
AS-40014	Crossbar, Platform	2
AS-40016	Channel, Kneebrace, Platform	4
AS-40015	Bracket, Tiebrace, Platform	2
3/8-16x1SFB	3/8"-16 x 1" Flange Bolt	125
3/8-16SFN	3/8"-16 Whiz Lock Nut	125
AS-40017	Plank, Tread, 10x60x14ga	4
AS-40018	Angle, Post, Flared	4
AS-40021	Plate, Kickboard, Side	2
AS-40020	Plate, Kickboard, Entry	2
AS-40028	Walkaround Top Rail	2
5/16-18x3/4FB	5/16"-18 x 13/4" Flange Bolt	12
5/16-18SFN	5/16"-18 Whiz Lock Nut	12
AS-40010	1 in Railing, Rest Landing Swivel Elbow	2
TRS1505900	59" Smashed Handrail 1.5" Diameter	2
AS-40009	1.5 Railing, Rest Landing Swivel Elbow	2
AS-40011	1.5 Railing End 90deg	2
AS-40012	1 in Railing End 90deg	2
HRC1500	1.5" Handrail Clamp	2
HRC1000	1" Handrail Clamp	2
Floor Screw	Self-Tapping Screw	8
AS-40030	Tread, Landing Skin	1
AS-40036	Channel Landing Support	4

Step 1 - AWT8544 - End Platform

- A. Attach an AS-40014 cross brace to wall bracket AS-40013. Secure using four (4) 3/8" Flange Bolts and four (4) 3/8" Lock Nuts. Refer to Detail C.
- B. Attach an AS-40015 cross brace to wall bracket AS-40013, as shown in Figure 1. Secure using four (4) 3/8" Flange Bolts and four (4) 3/8" Lock Nuts.
- C. Attach the lower AS-40016 to wall bracket AS-40013. Refer to Detail B. Secure using two (2) 3/8" Flange Bolts and two (2) 3/8" Lock Nuts. The flanges on the AS-40016 will be facing to the right, when looking at the bracket head-on.
- D. Attach the upper AS-40016 to cross brace AS-40014. Refer to Detail D. The flanges on the AS-40016 will be facing to the left. Secure using two (2) 3/8" Flange Bolts and two (2) 3/8" Lock Nuts.
- E. Repeat steps A through D for the next wall bracket assembly.
- F. Attach each wall bracket to the bin using no fewer than eight (8) 3/8" Bin Bolts and eight (8) 3/8" Lock Nuts on each bracket. Using fewer than sixteen (16) total will restrict loading limits and compromise safety. Drilling may be required.
- G. Bracket spacing should be four (4) or five (5) bolt spaces apart. Four (4) if the bin diameter is at or below 48', five (5) if the bin diameter exceeds it.

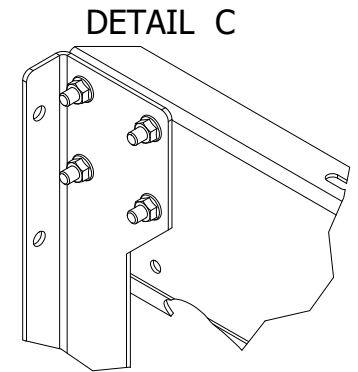
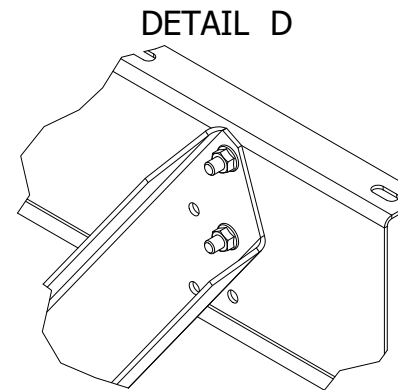
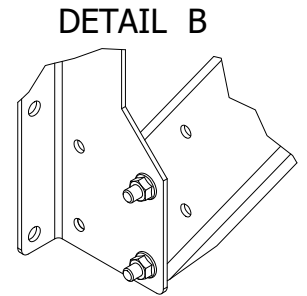
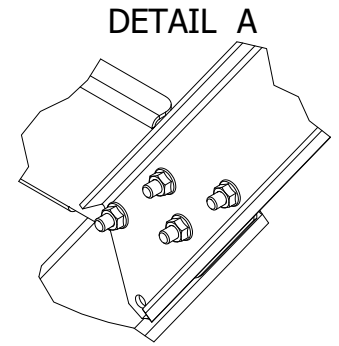
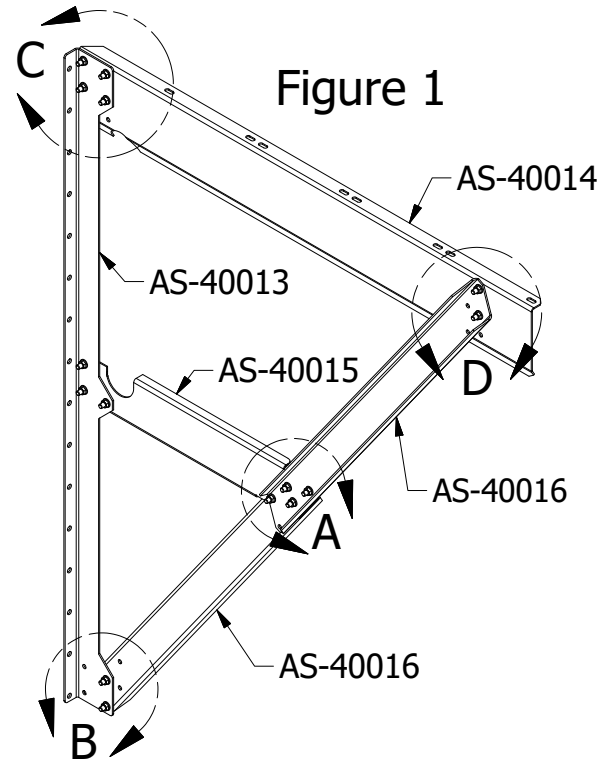

PARTS USED IN STEP 1

PART NUMBER	DESCRIPTION	QTY
AS-40013	Bracket, Wall, Platform 44" ring	2
AS-40014	Crossbar, Platform	2
AS-40016	Channel, Kneebrace, Platform	4
AS-40015	Bracket, Tiebrace, Platform	2
3/8-16x1SFB	3/8"-16 x 1" Flange Bolt	34
3/8-16SFN	3/8"-16 Whiz Lock Nut	34

DRAWN Marcus Wilmsmeyer	6/5/2018	Greene Galvanized Stairs East Lynn, IL 217.375.4244 www.greenebinstairs.com	
CHECKED		TITLE AWT Platform Assembly Instructions	
QA		SIZE A	DWG NO IN-AWT8044
MFG		SCALE 1/15	REV
APPROVED		SHEET 5 OF 12	

Step 1 - AWT8644 - Through Platform

- A. Attach an AS-40014 cross brace to wall bracket AS-40013. Secure using four (4) 3/8" Flange Bolts and four (4) 3/8" Lock Nuts. Refer to Detail C.
- B. Attach an AS-40015 cross brace to wall bracket AS-40013, as shown in Figure 1. Secure using four (4) 3/8" Flange Bolts and four (4) 3/8" Lock Nuts.
- C. Attach the lower AS-40016 to wall bracket AS-40013. Refer to Detail B. Secure using two (2) 3/8" Flange Bolts and two (2) 3/8" Lock Nuts. The flanges on the AS-40016 will be facing to the right, when looking at the bracket head-on.
- D. Attach the upper AS-40016 to cross brace AS-40014. Refer to Detail D. The flanges on the AS-40016 will be facing to the left. Secure using two (2) 3/8" Flange Bolts and two (2) 3/8" Lock Nuts.
- E. Repeat steps A through D for the next wall bracket assembly.
- F. Attach each wall bracket to the bin using no fewer than eight (8) 3/8" Bin Bolts and eight (8) 3/8" Lock Nuts on each bracket. Using fewer than sixteen (16) total will restrict loading limits and compromise safety. Drilling may be required.
- G. Bracket spacing should be four (4) or five (5) bolt spaces apart. Four (4) if the bin diameter is at or below 48', five (5) if the bin diameter exceeds it.

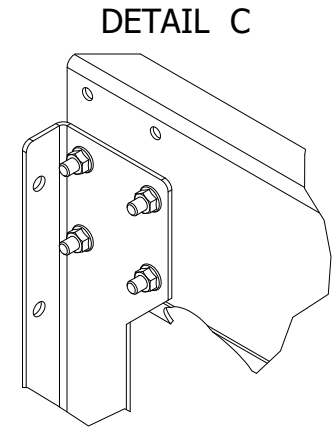
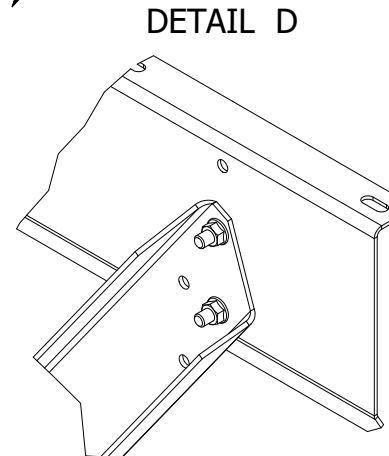
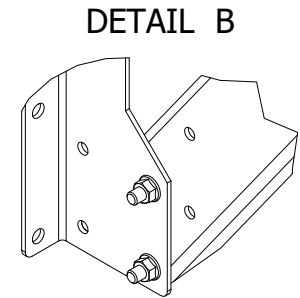
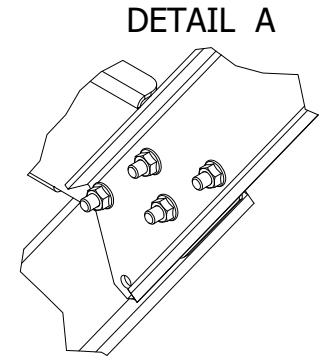
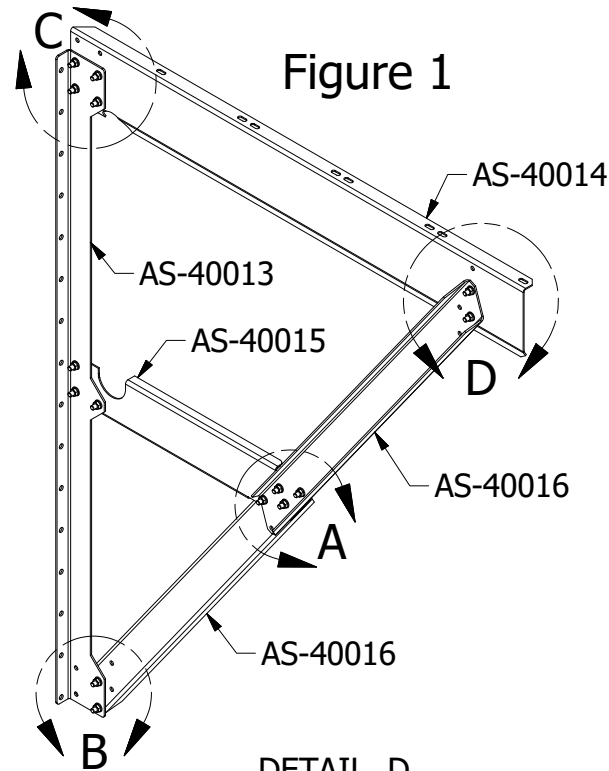

PARTS USED IN STEP 1

PART NUMBER	DESCRIPTION	QTY
AS-40013	Bracket, Wall, Platform 44" ring	2
AS-40014	Crossbar, Platform	2
AS-40016	Channel, Kneebrace, Platform	4
AS-40015	Bracket, Tiebrace, Platform	2
3/8-16x1SFB	3/8"-16 x 1" Flange Bolt	34
3/8-16SFN	3/8"-16 Whiz Lock Nut	34

DRAWN Marcus Wilmsmeyer	6/5/2018	Greene Galvanized Stairs East Lynn, IL 217.375.4244 www.greenebinstairs.com	
CHECKED		TITLE AWT Platform Assembly Instructions	
QA		SIZE A	DWG NO IN-AWT8044
MFG		SCALE 1/15	REV
APPROVED		SHEET 6 OF 12	

Bracket Comparison

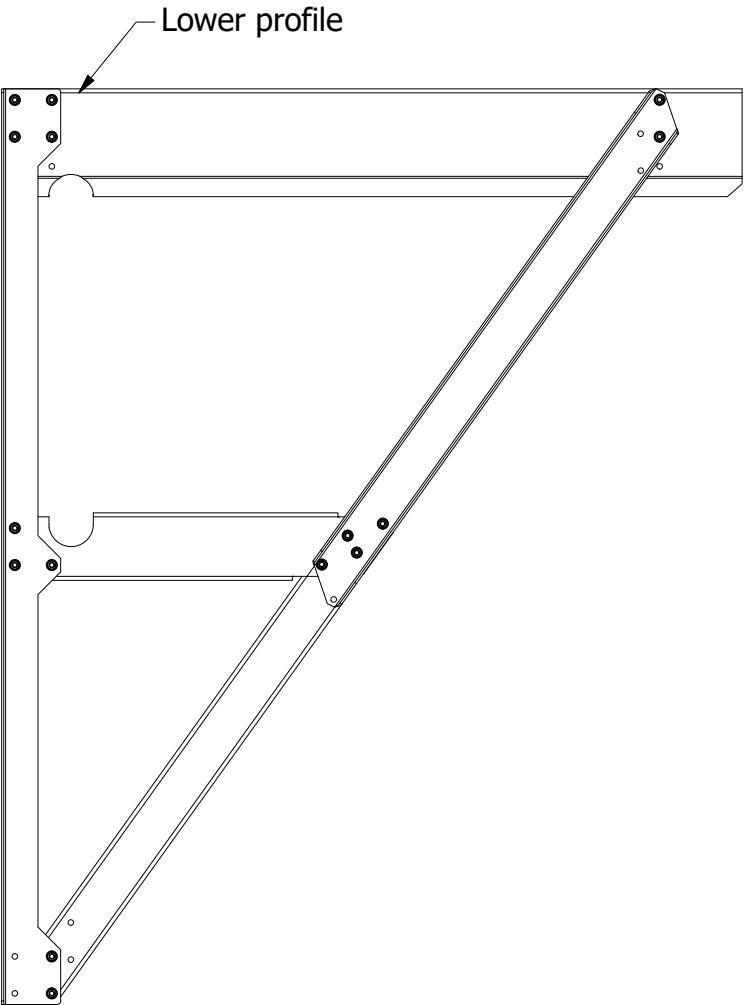

AWT8544 End Platform Bracket

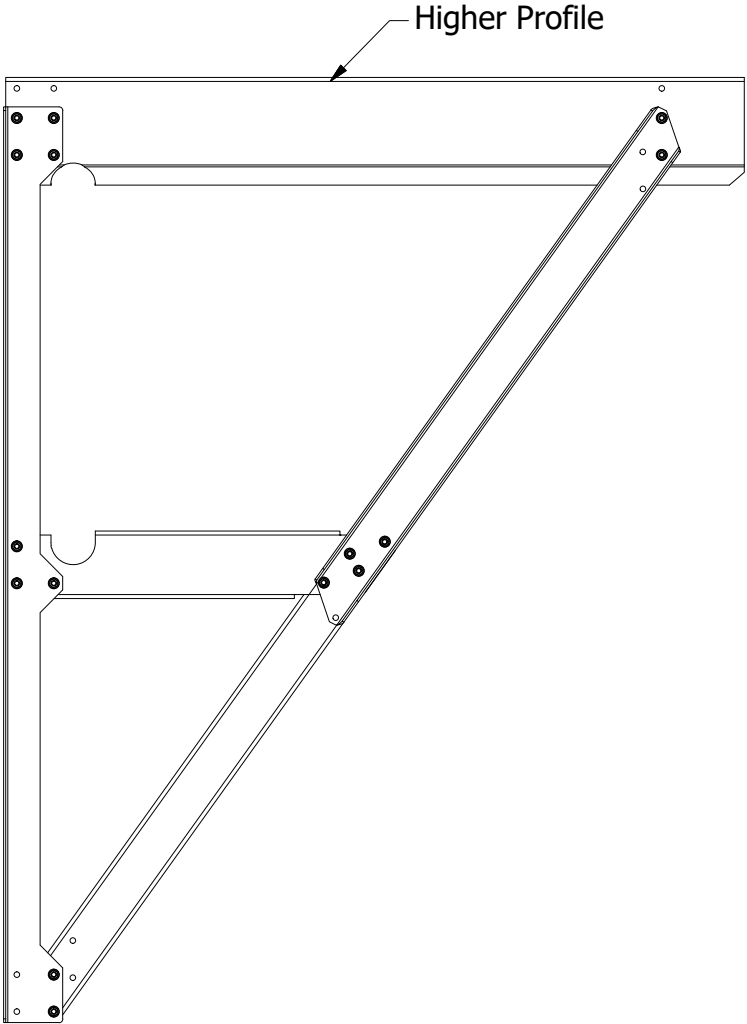

AWT8644 Through Platform Bracket

DRAWN Marcus Wilmsmeyer	6/5/2018	Greene Galvanized Stairs East Lynn, IL 217.375.4244 www.greenebinstairs.com	
CHECKED		TITLE	
QA		AWT Platform Assembly	
MFG		Instructions	
APPROVED		SIZE	DWG NO
		A	IN-AWT8044
		SCALE	REV
		1/13	
		SHEET	OF
		7	12

Step 2

- A. Center and place the four AS-40017 deck planks on top of the wall brackets assembled in Step 1.
- B. Secure in place using sixteen (16) 3/8" Flange Bolts and sixteen (16) 3/8" Lock Nuts, as shown in Detail E.
- C. Using twenty-one (21) 3/8" Flange Bolts and twenty-one (21) 3/8" Lock Nuts, secure the four AS-40017 deck planks together.

Figure 2

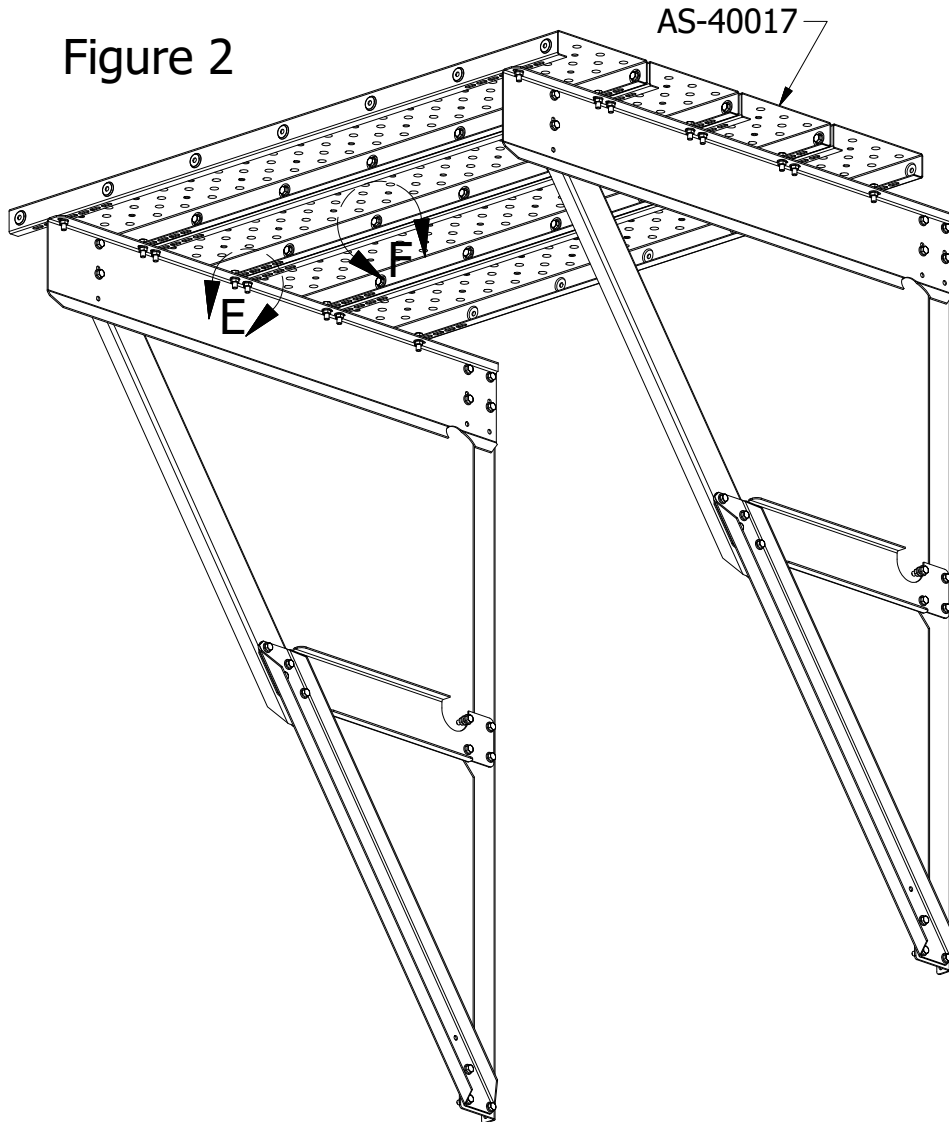

DETAIL E

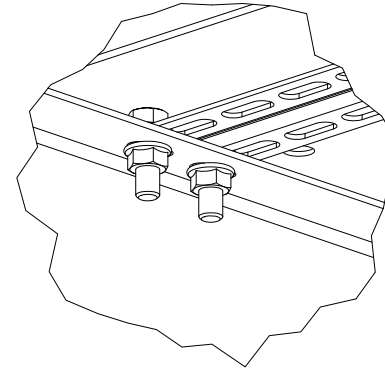

DETAIL F

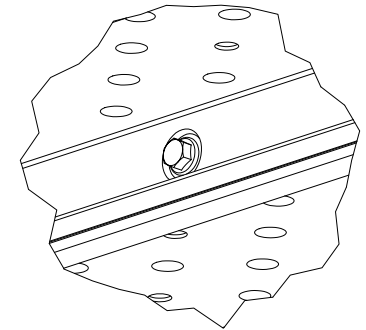

PARTS USED IN STEP 2

PART NUMBER	DESCRIPTION	QTY
AS-40017	Deck Plank Tread	4
3/8-16x1SFB	3/8"-16 x 1" Flange Bolt	37
3/8-16SFN	3/8"-16 Whiz Lock Nut	37

DRAWN Marcus Wilmsmeyer	6/5/2018	Greene Galvanized Stairs East Lynn, IL 217.375.4244 www.greenebinstairs.com	
CHECKED		TITLE AWT Platform Assembly Instructions	
QA		SIZE A	DWG NO IN-AWT8044
MFG		SCALE 1/15	REV
APPROVED		SHEET 8 OF 12	

Step 3

- A. Place the AS-40020 front kickboard along the front of the deck. The top flange should be facing away from the deck planks.
- B. Take the four AS-40018 posts and mount them on the deck planks. On the posts, the second hole from the bottom will line up with the deck planks.
- C. Place the AS-40021 kickboards along the side holes on the deck plank, and secure the AS-40021 and AS-40018 components using eleven (11) 3/8" Flange Bolts and eleven (11) 3/8" Lock Nuts on each side. Refer to Figure 3.
- D. Bolt two AS-40018 posts to the AS-40020 using eight (8) 3/8" Flange Bolts and eight (8) 3/8" Lock Nuts.

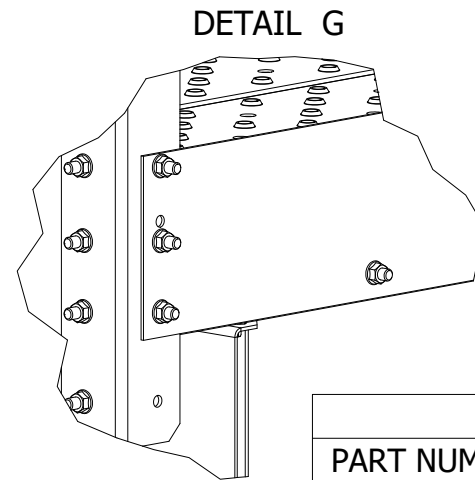
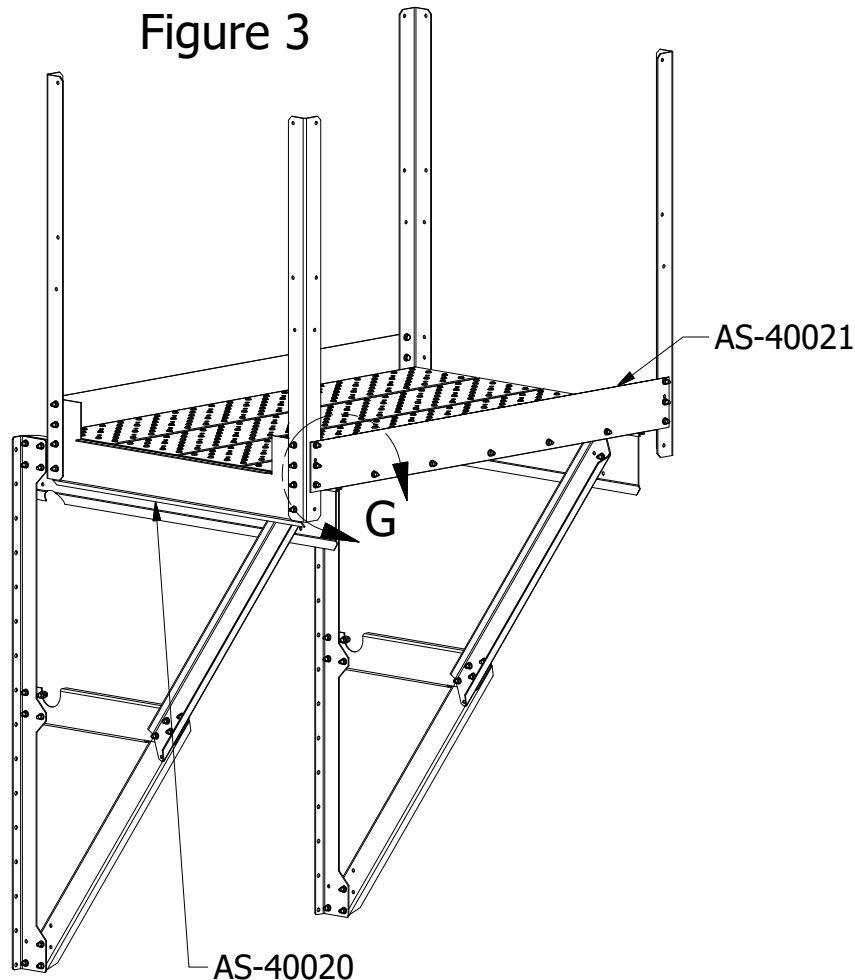

PARTS USED IN STEP 3

PART NUMBER	DESCRIPTION	QTY
AS-40018	Flared Angle Post	4
AS-40021	Platform Side Kickboard	2
AS-40020	Plate, Kickboard, Entry	1
3/8-16x1SFB	3/8"-16 x 1" Flange Bolt	30
3/8-16SFN	3/8"-16 Whiz Lock Nut	30

DRAWN Marcus Wilmsmeyer	6/5/2018	Greene Galvanized Stairs East Lynn, IL 217.375.4244 www.greenebinstairs.com	
CHECKED		TITLE AWT Platform Assembly Instructions	
QA		SIZE A	DWG NO IN-AWT8044
MFG		SCALE 1/22	REV
APPROVED		SHEET 9 OF 12	

Step 4

- A. Place end kickboard AS-40019 on the end of the platform. For the AWT8644, instead of an end kickboard, it will be an entry kickboard, part AS-40020.
- B. Secure in place using eight (8) 3/8" Flange Bolts and eight (8) 3/8" Lock Nuts.
- C. Place the two (2) AS-40031 handrail platform brackets onto the two (2) AS-40018 entry posts. Refer to Figure 4 for placement.
- D. Secure the brackets to the posts using three (3) 5/16" Flange Bolts and three (3) 5/16" Lock Nuts on each bracket, for a total of six (6).
- E. Place the AS-40028 handrails and ASL-2001 handrails on the posts. The AWT8644 will not have ASL-2001 rails, as it is a through platform.
- F. Secure them in place with eight (8) 5/16" Flange Bolts and eight (8) 5/16" Lock Nuts.

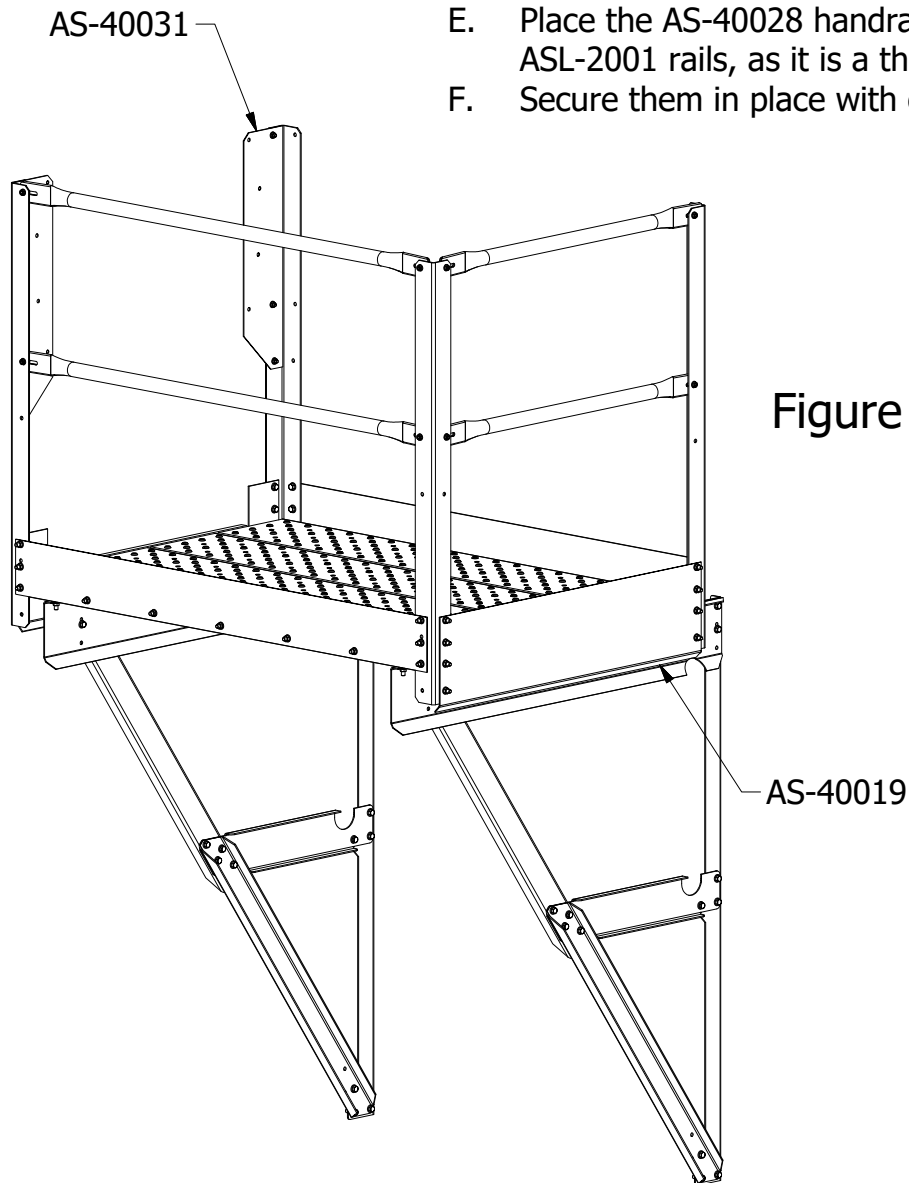

Figure 4

PARTS USED IN STEP 4		
PART NUMBER	DESCRIPTION	QTY
3/8-16x1SFB	3/8"-16 x 1" Flange Bolt	8
3/8-16SFN	3/8"-16 Whiz Lock Nut	8
AS-40019	End Kickboard	1
AS-40031	Platform Handrail Bracket	2
5/16-18x3/4FB	5/16"-18 x 13/4" Flange Bolt	14
5/16-18SFN	5/16"-18 Whiz Lock Nut	14
TRS1505900	59" Smashed Handrail 1.5" Dia.	2
TRS1504000	40" Smashed Handrail 1.5" Dia.	2

DRAWN Marcus Wilmsmeyer	6/5/2018	Greene Galvanized Stairs East Lynn, IL 217.375.4244 www.greenebinstairs.com	
CHECKED		TITLE AWT Platform Assembly Instructions	
QA		SIZE A	DWG NO IN-AWT8044
MFG		SCALE 1/20	REV
APPROVED		SHEET 10 OF 12	

Step 5

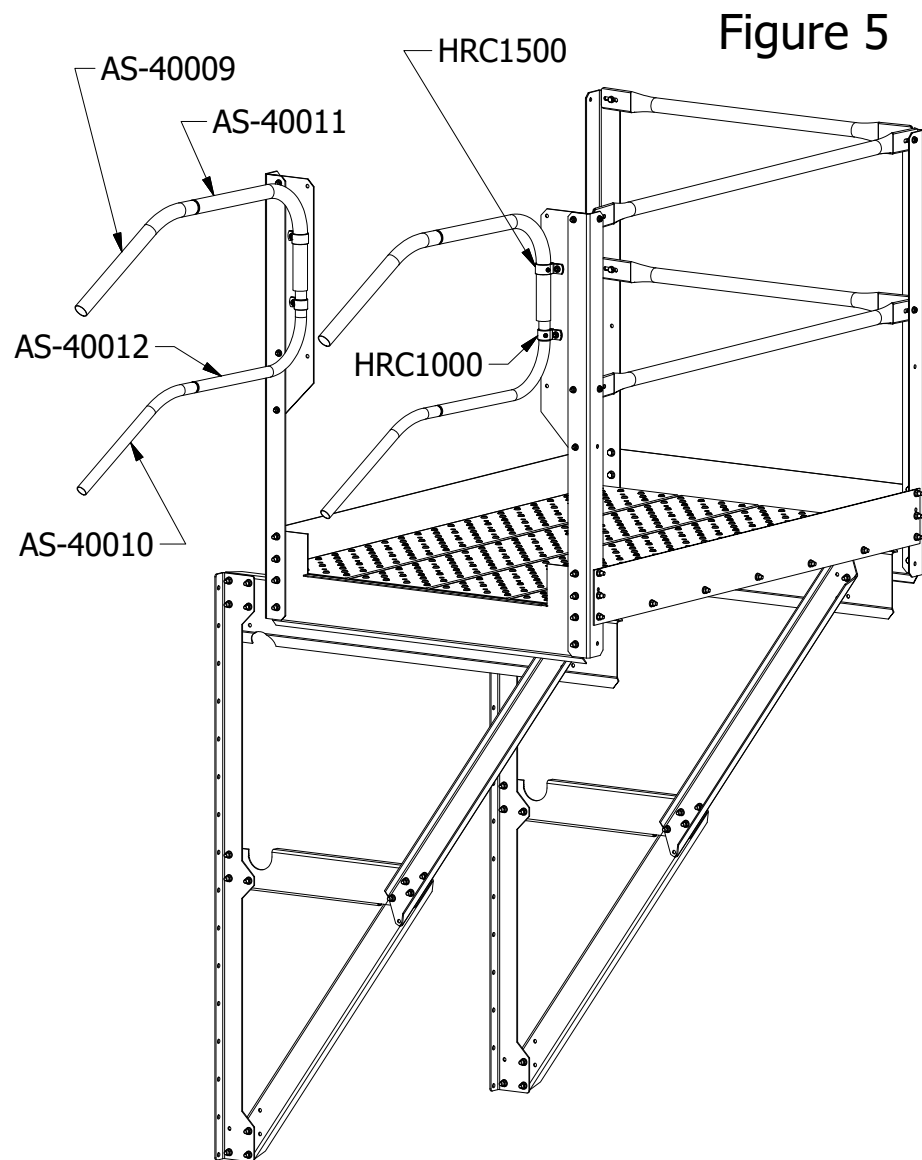

Figure 5

- A. Attach AS-40011 to the vertical post using an HRC1500 handrail clamp and a 5/16" Flange Bolt and 5/16" Lock Nut.
- B. Insert AS-40012 into rail AS-40011, and attach to the vertical post using an HRC1000 handrail clamp and a 5/16" Flange Bolt and 5/16" Lock Nut.
- C. Insert the swaged end of handrail AS-40010 into AS-40012, and AS-40009 into AS-40011.
- D. The top of the upper handrail should be 42" (1,067 mm) above the platform tread, and the top of the intermediate rail should be 21" (533 mm) above the platform tread.
- E. Ensure the rails are level, and secure AS-40010 to AS-40012 with a Tech Screw, and AS-40009 to AS-40011 with another Tech Screw.
- F. Repeat A-D for the other handrail.

PARTS USED IN STEP 5		
PART NUMBER	DESCRIPTION	QTY
AS-40010	1 in Railing, Rest Landing Swivel Elbow	2
AS-40009	1.5 Railing, Rest Landing Swivel Elbow	2
AS-40011	1.5 Railing End 90deg	2
AS-40012	1 in Railing End 90deg	2
HRC1500	1.5" Handrail Clamp	2
HRC1000	1" Handrail Clamp	2
Floor Screw	Self-Tapping Screw	8

DRAWN Marcus Wilmsmeyer	6/5/2018	Greene Galvanized Stairs East Lynn, IL 217.375.4244 www.greenebinstairs.com	
CHECKED		TITLE AWT Platform Assembly Instructions	
QA		SIZE A	DWG NO IN-AWT8044
MFG		SCALE 1/20	REV
APPROVED		SHEET 11 OF 12	

Step 6

PARTS USED IN STEP 6

PART NUMBER	DESCRIPTION	QTY
3/8-16x1SFB	3/8"-16 x 1" Flange Bolt	4
3/8-16SFN	3/8"-16 Whiz Lock Nut	4
5/16-18x3/4FB	5/16"-18 x 13/4" Flange Bolt	12
5/16-18SFN	5/16"-18 Whiz Lock Nut	12
AS-40030	Tread, Landing Skin	1
AS-40036	Channel Landing Support	4

Figure 6

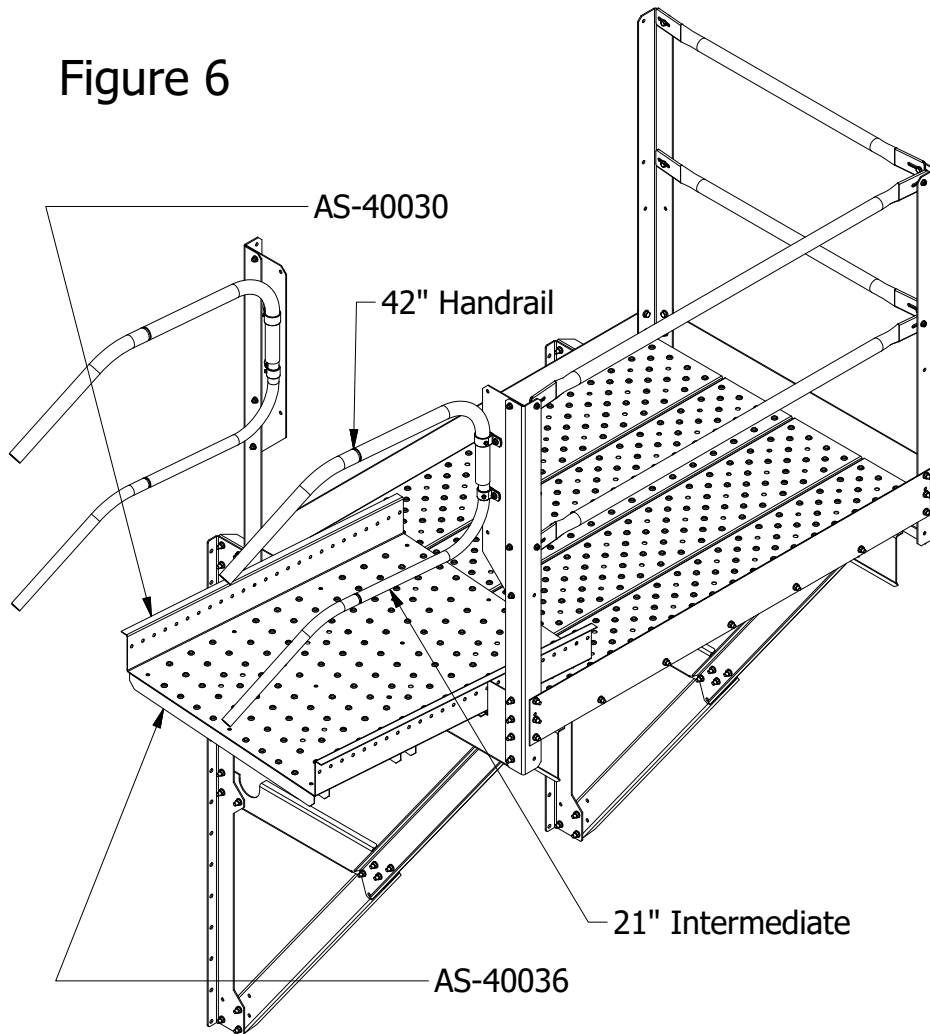

- A. Attach braces AS-40036 to the platform skin AS-40030. Each installation will be different, but usually two braces will suffice.
- B. Secure in place with three (3) Pan Head Bolts and three (3) Lock Nuts for each brace.
- C. Line up the platform skin with the previous stair section, and bolt in using four (4) 3/8" Flange Bolts and four (4) 3/8" Lock Nuts.
- D. After final adjustments have been made for the stairs, secure the platform skin (AS-40030) to the platform using three (3) Floor Screws.

DRAWN Marcus Wilmsmeyer	6/5/2018	Greene Galvanized Stairs East Lynn, IL 217.375.4244 www.greenebinstairs.com	
CHECKED		TITLE	
QA		AWT Platform Assembly	
MFG		Instructions	
APPROVED		SIZE A	DWG NO IN-AWT8044
		SCALE 1/20	REV
		SHEET 12	OF 12