

IN-AVT1603

Greene Galvanized Stairs

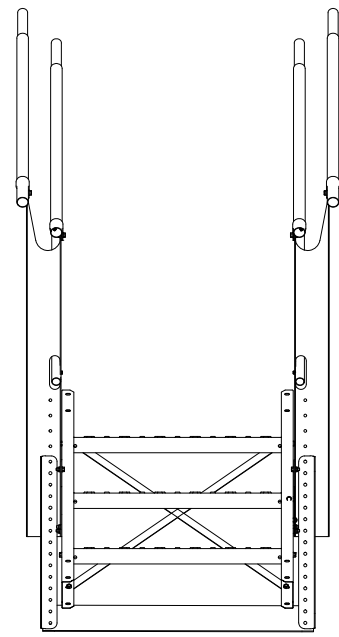
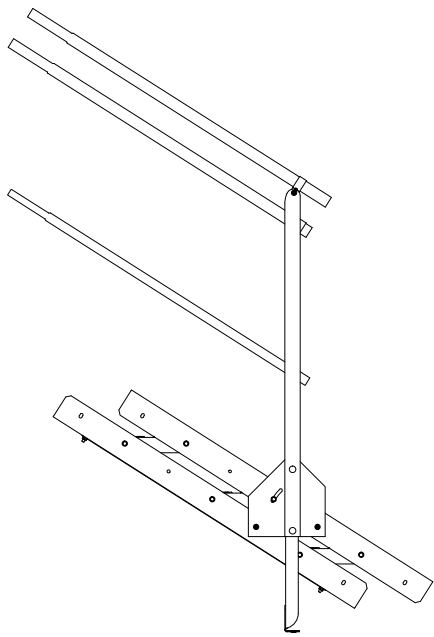
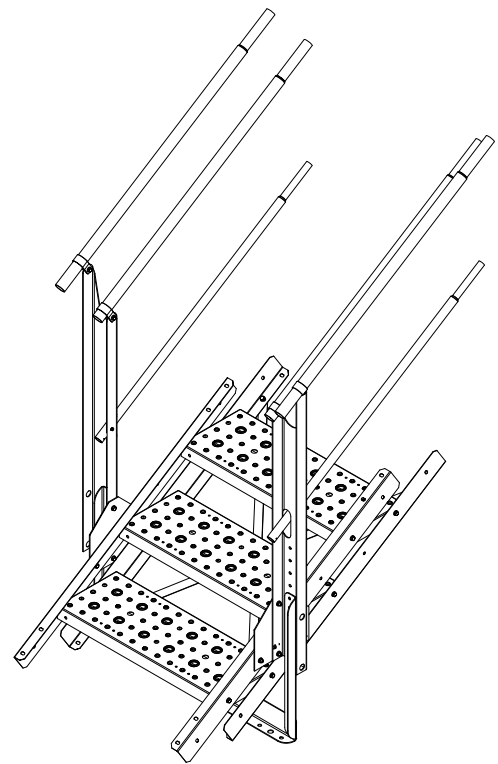

PARTS LIST			
ITEM	QTY	PART NUMBER	DESCRIPTION
2	4	ART-5003	3 step side rail
3	3	AS00030	Tread 30 x 11 Step Assembly
4	12	5/16-18x3/4FB	5/16"-18 x 3/4" Flange Bolt
5	12	5/16-18SFN	5/16"-18 Whiz Lock Nut
6	2	ART-1001	Stair Stringer X-Brace
7	4	TR1504606	46 in x1.5 in Railing 6 in Swage
8	2	TR1004606	46 in 1 in dia tubing 6in swage
9	4	HRC1500	Handrail Clamp for 1.5 in
10	2	Floorscrew	Self tapping screw
11	1	ART-1106	Cross Mount Foot
12	2	ART-1105	Post Extension

# Parts List

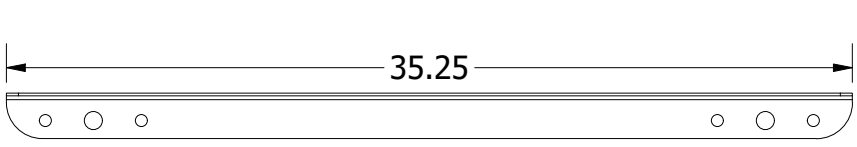

ART-1106

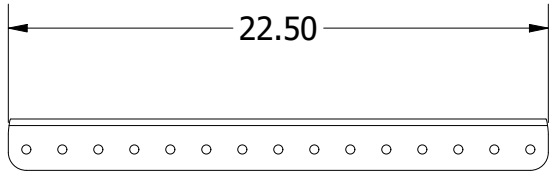

ART-1105

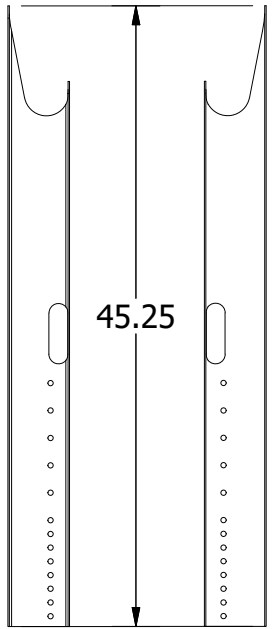

ART-1016    ART-1015

HRC1500

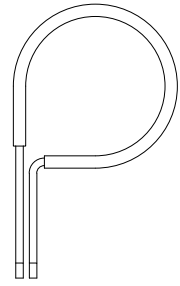

ART-1011

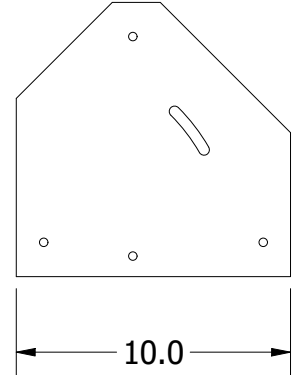

1.51

TR1504606

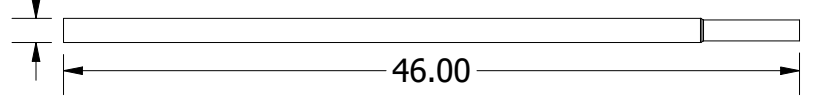

1.16

TR1004606

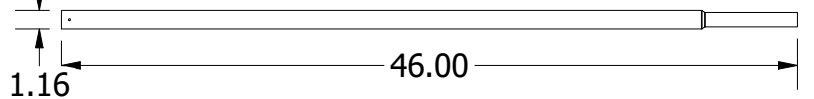

AS00030

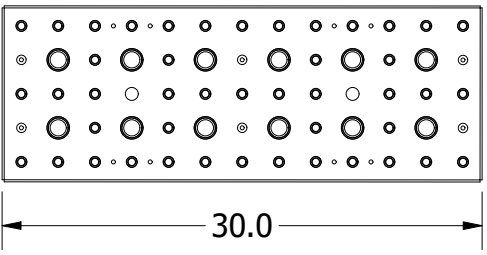

ART-1001

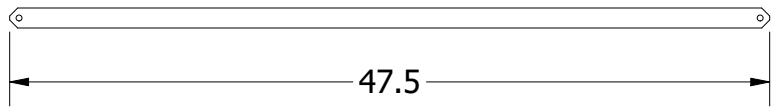

5/16-18x3/4FB

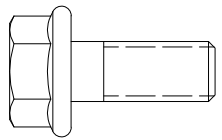

1:1

5/16-18SFN

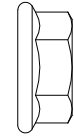

1:1

Floor Screw

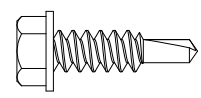

1:1

ART-5003

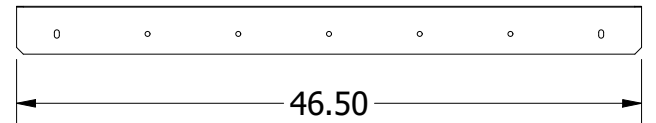

All units in inches

# Step 1: Adding the Levelling Brackets

- A. Take two (2) ART-1011 Levelling Brackets and attach them to the ART-1015 and ART-1016 posts as shown in Figure 3 and Figure 4.
- B. Secure the brackets in place using four (4) 5/16" Flange Bolts and four (4) 5/16" Lock Nuts.

PARTS USED		
PART NUMBER	DESCRIPTION	QTY
5/16-18x3/4FB	5/16"-18 x 3/4" Flange Bolt	4
5/16-18SFN	5/16"-18 Whiz Lock Nut	4
ART-1016	Post, Stair Rail, Guard Rail Right	1
ART-1015	Post, Stair Rail, Guard Rail Left	1
ART-1011	Roof Stair Leveling Plate	2

Figure 3

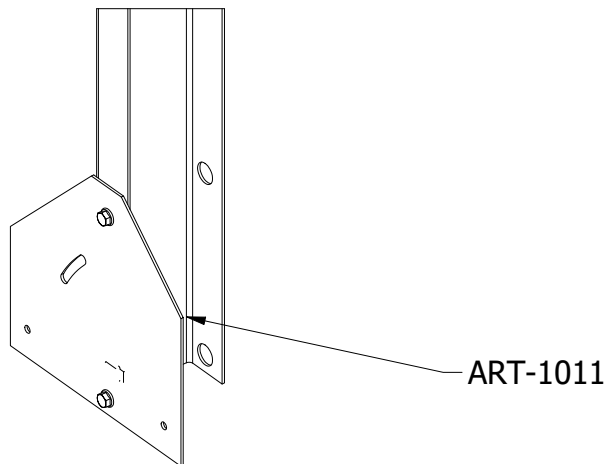
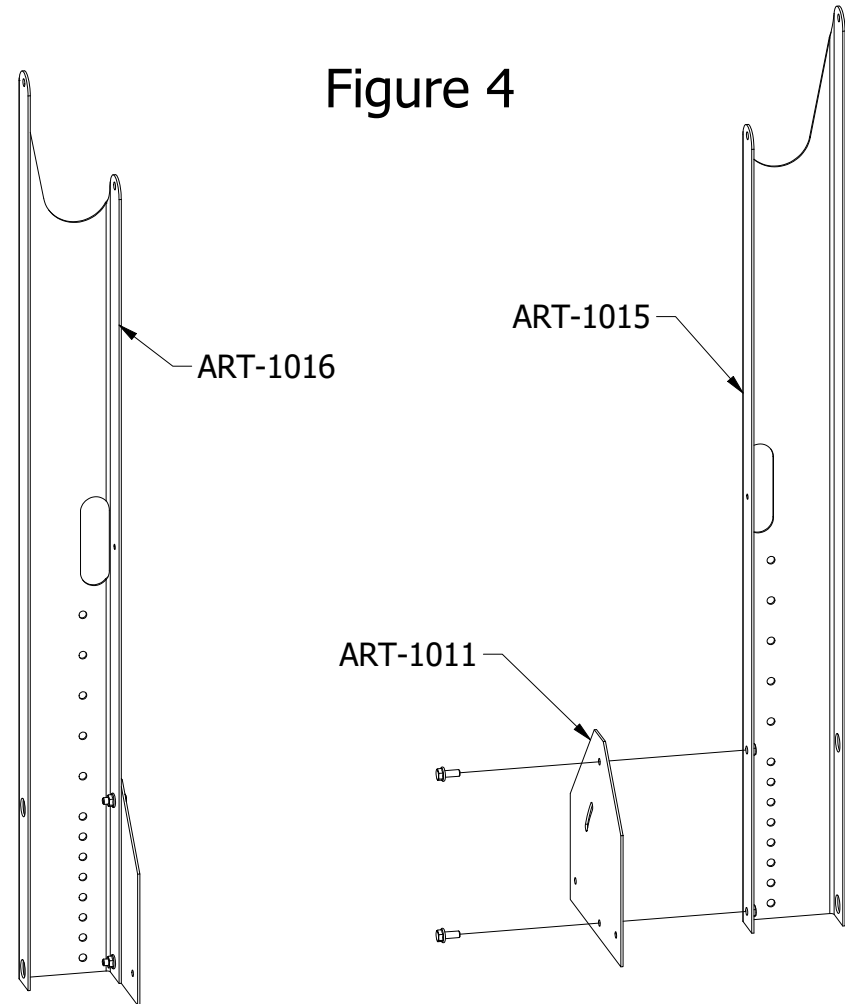

Figure 4



## Step 2: Adding the Step Tread and Siderail

- A. Place (3) AS00030 Step Treads in line with (4) ART-5003 Siderails shown.
- B. Using (6) 5/16" Flange Bolts and (6) 5/16" Lock Nuts, secure the step treads to the siderails. On the second-lowest stair, omit two of the bolts and nuts; they will be added on a later step.

PARTS LIST		
PART NUMBER	DESCRIPTION	QTY
ART5003	3-Step End Side Rail	4
AS00030	Tread 30 x 11 Step Assembly	3
5/16-18x3/4 FB	5/16"-18 x 3/4" Flange Bolt	12
5/16-18SFN	5/16"-18 Whiz Lock Nut	12

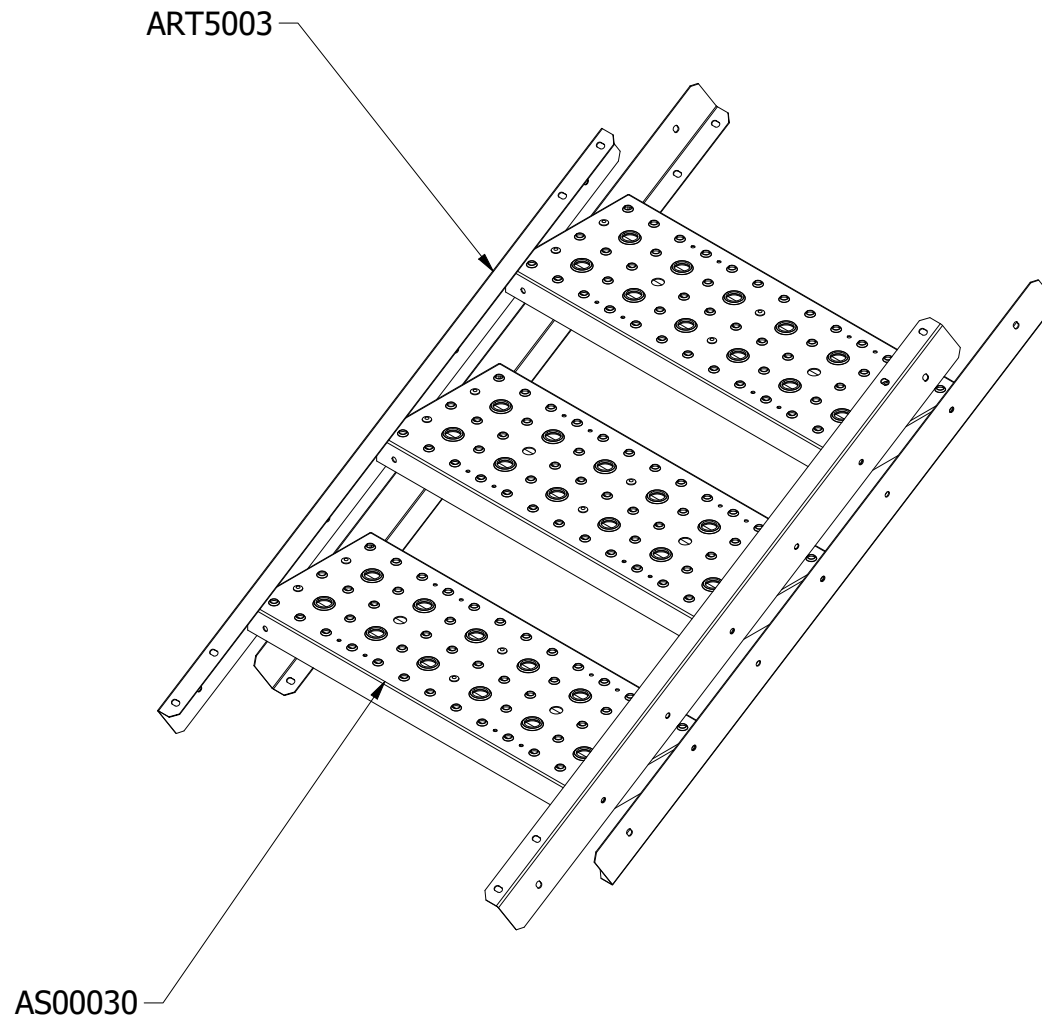

## Step 3 : Adding the X-Brace

- A. Take the two (2) ART-1001 and position them on the bottom of the stair assembly as shown in Figure .
- B. Secure in place with four (4) 5/16" Flange Bolts and four (4) 5/16" Lock Nuts.

PARTS LIST		
PART NUMBER	DESCRIPTION	QTY
5/16-18x3/4FB	5/16"-18 x 3/4" Flange Bolt	12
5/16-18SFN	5/16"-18 Whiz Lock Nut	12
ART-1001	Stair Stringer X-Brace	2

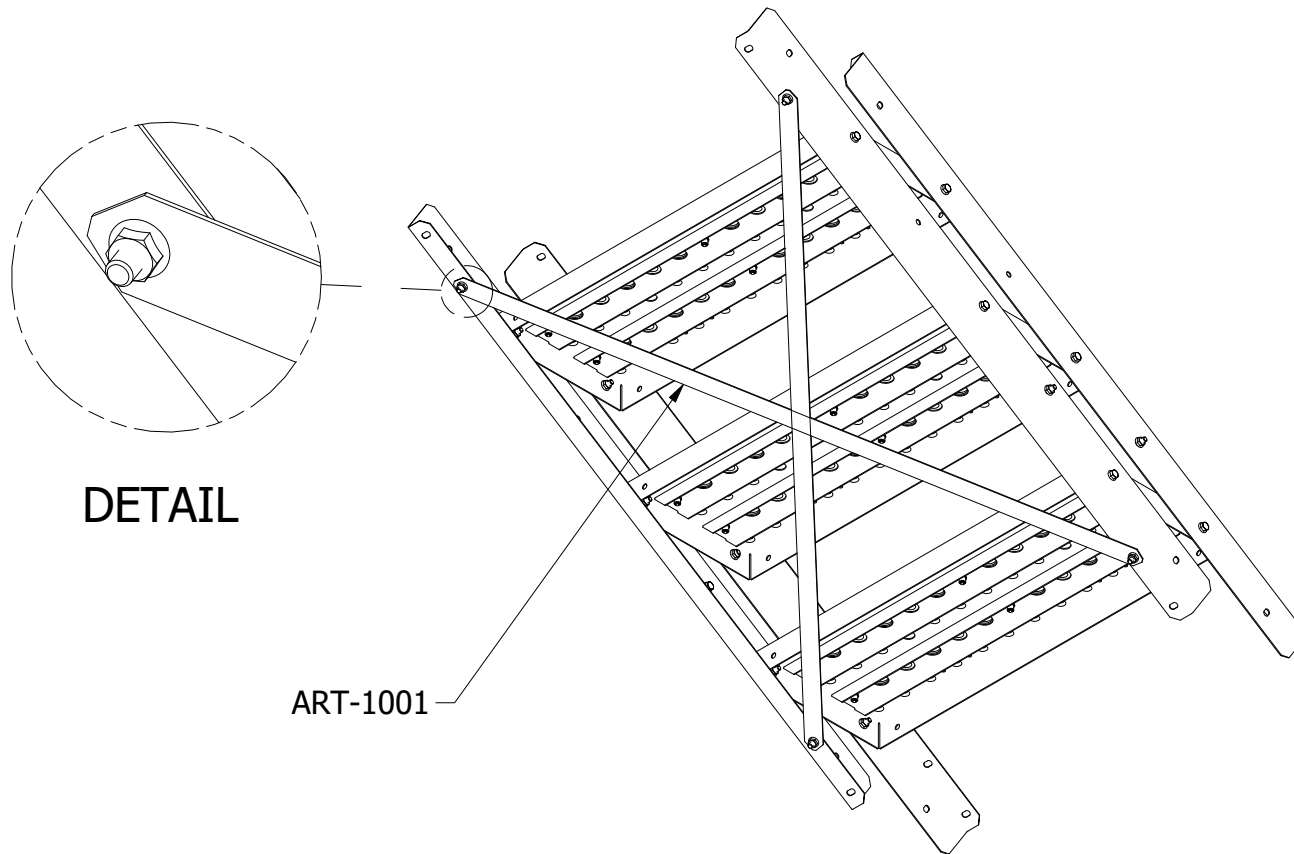

# STEP 4: Attaching Leveling plates to the siderail

- A. Using six (6) 5/16" Flange Bolts and six (6) 5/16" Lock Nuts, bolt the siderails to the leveling bracket. Review Figure 6 and Figure 7 bolt layout.
- B. Tighten the bolts on the leveling plates after the final placement.

PARTS USED IN STEP 4		
PART NUMBER	DESCRIPTION	QTY
5/16-18x3/4FB	5/16"-18 x 3/4" Flange Bolt	6
5/16-18SFN	5/16"-18 Whiz Lock Nut	6

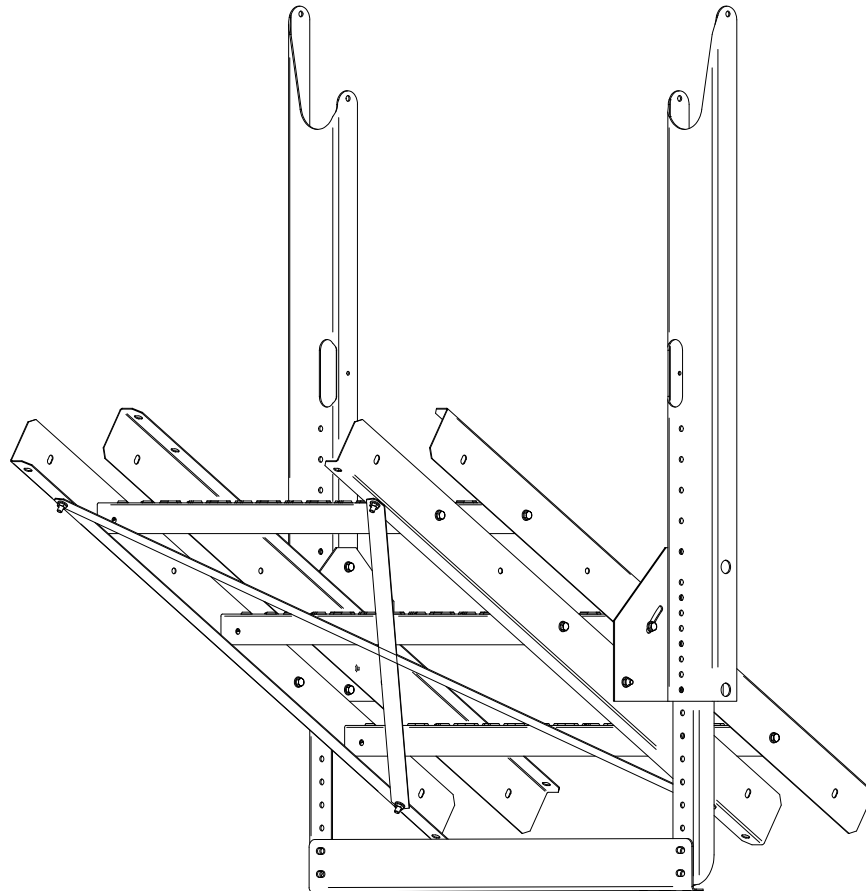

# STEP 5: Attaching Handrail and Guardrail

- A. Taking the four (4) TR1504606 Swaged Pipes (1.5" dia.), position the pipes as shown in the Figure. Secure the pipes to the posts using four (4) HRC1500 P-Clamps, four (4) 5/16" Flange Bolts, and four (4) 5/16" Lock Nuts.
- B. After the four TR1504606 have been position to the desired location, use four (4) Self-Tapping Screws and secure the 1.5" pipe to the P-Clamp. The screws should be drilled through the bottom of the P-clamp, to minimize interference with hands.
- C. Take the two (2) TR1004606 Swaged Pipes (1" dia.), and position them as shown in Figure. Secure them to the posts by using two (2) Self-Tapping Screws. There is a hole on the post to aid in starting the Self-Tapping Screw.

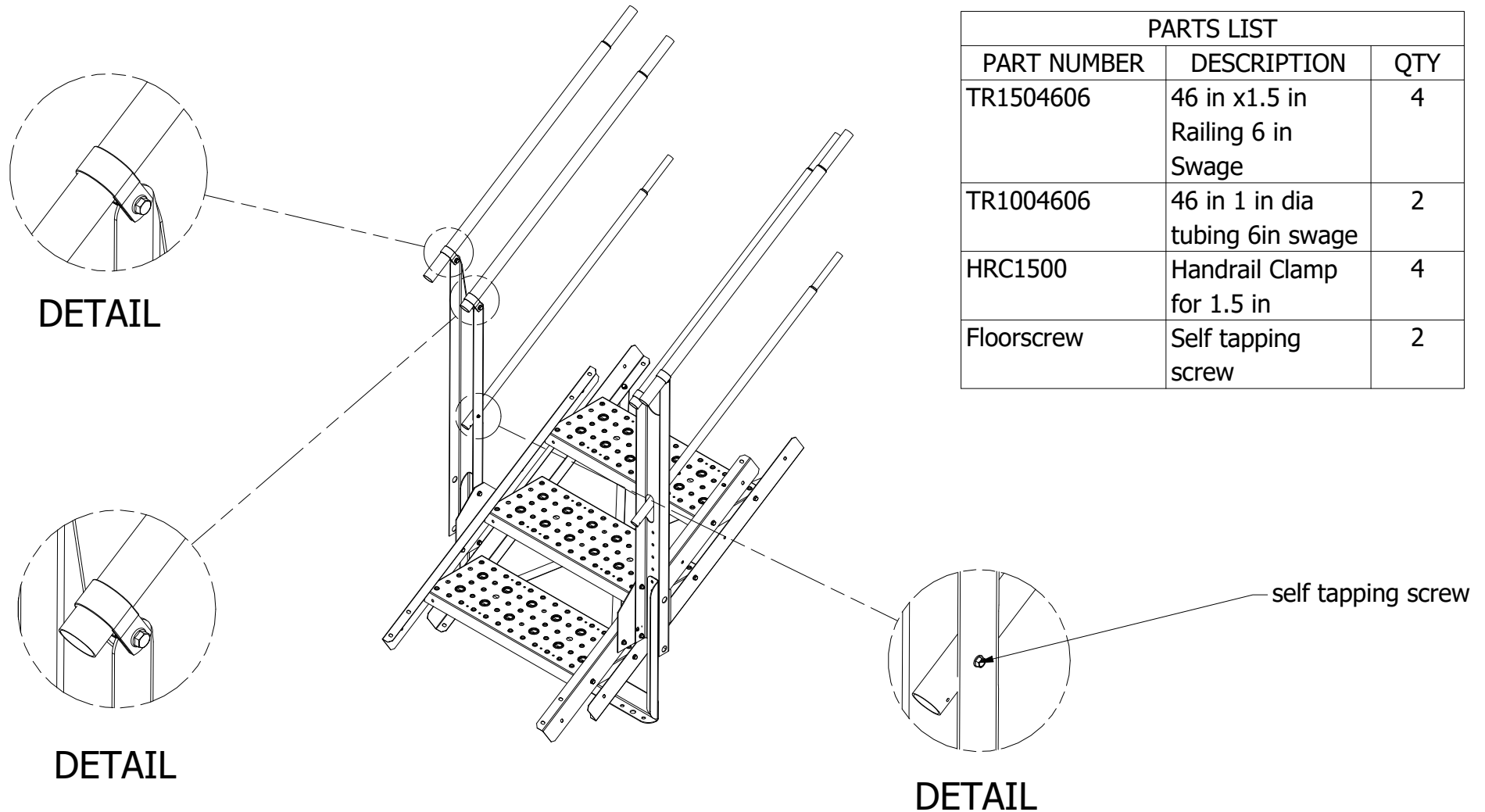



# Sample 22 Step Assembly - ( applies to multiple step package assemblies including 17,20,21 step assemblies)

