

ATS0013 - Parts List

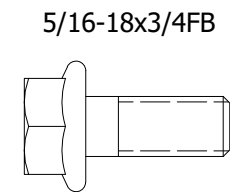
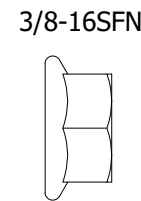
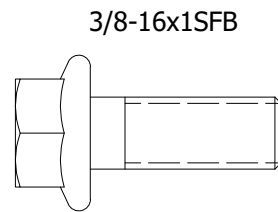
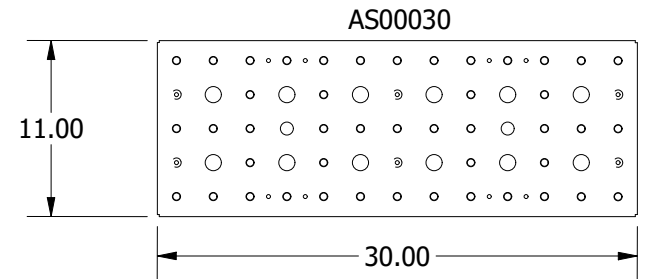
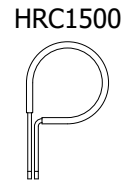
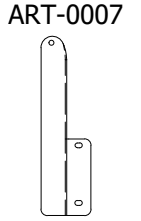
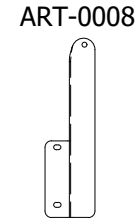
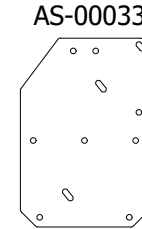
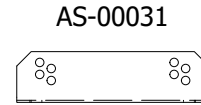
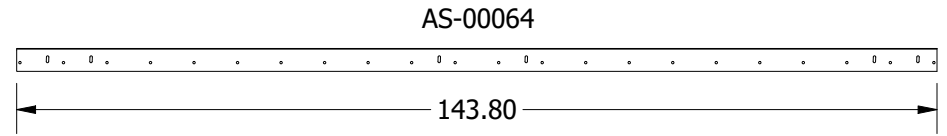
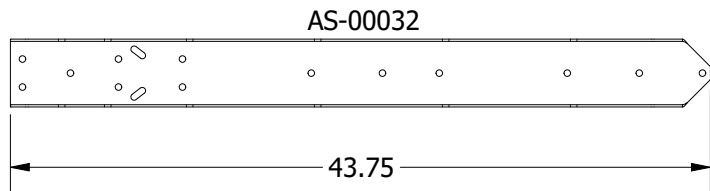
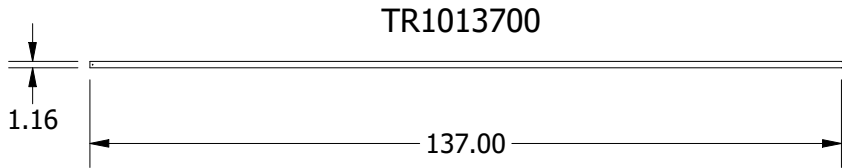
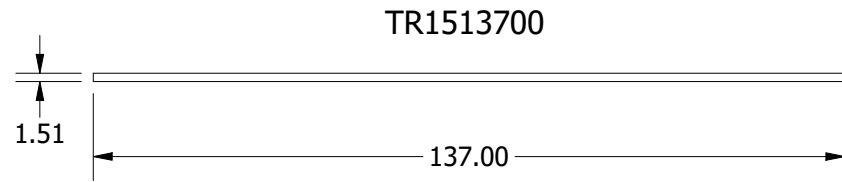

PARTS LIST

ITEM	QTY	PART NUMBER	DESCRIPTION
1	6	AS-00033	Bracket Leveling Plate Upper
2	6	AS-00032	Channel Post Stair VP
3	2	AS-00031	Angle Starter Anchor
4	2	TR1513700	137 in x1.5 in Railing No Swage
5	4	TR1013700	137 in x1 in Railing No Swage
6	11	AS00030	Tread 30 x 11 Step Assembly
7	6	HRC1500	Handrail Clamp for 1.5 in
8	12	HRC1000	Handrail Clamp for 1 in
9	2	AS-00064	Angle Starter Siderail VP 11 step
10	3	ART-0007	Entry Guardrail Post Right
11	3	ART-0008	Entry Guardrail Post Left
12	60	3/-16x1SFB	3/8"-16 x 1" Flange Bolt
13	60	3/8-16SFN	3/8"-16 Whiz Lock Nut
14	28	5/16-18SFN	5/16"-18 Whiz Lock Nut
15	28	5/16-18x3/4FB	5/16"-18 x 3/4" Flange Bolt
16	18	FloorScrews	Self-Tap Screws

Step 1

- A. Take the eleven (11) AS00030 step treads and place them along the AS-00064 siderails. The flange must be facing inward to the stairs.
- B. Use the holes on AS-00064 siderails to mount each AS00030 step tread.
- C. Secure in place with twenty-two (22) 3/8" Flange Bolts and twenty-two (22) 3/8" Lock Nuts. The bolts should be arranged so that the nuts are on the outside of the channel.

*Leave bolts on 1st, 6th, and 11th step loose for Step 3.

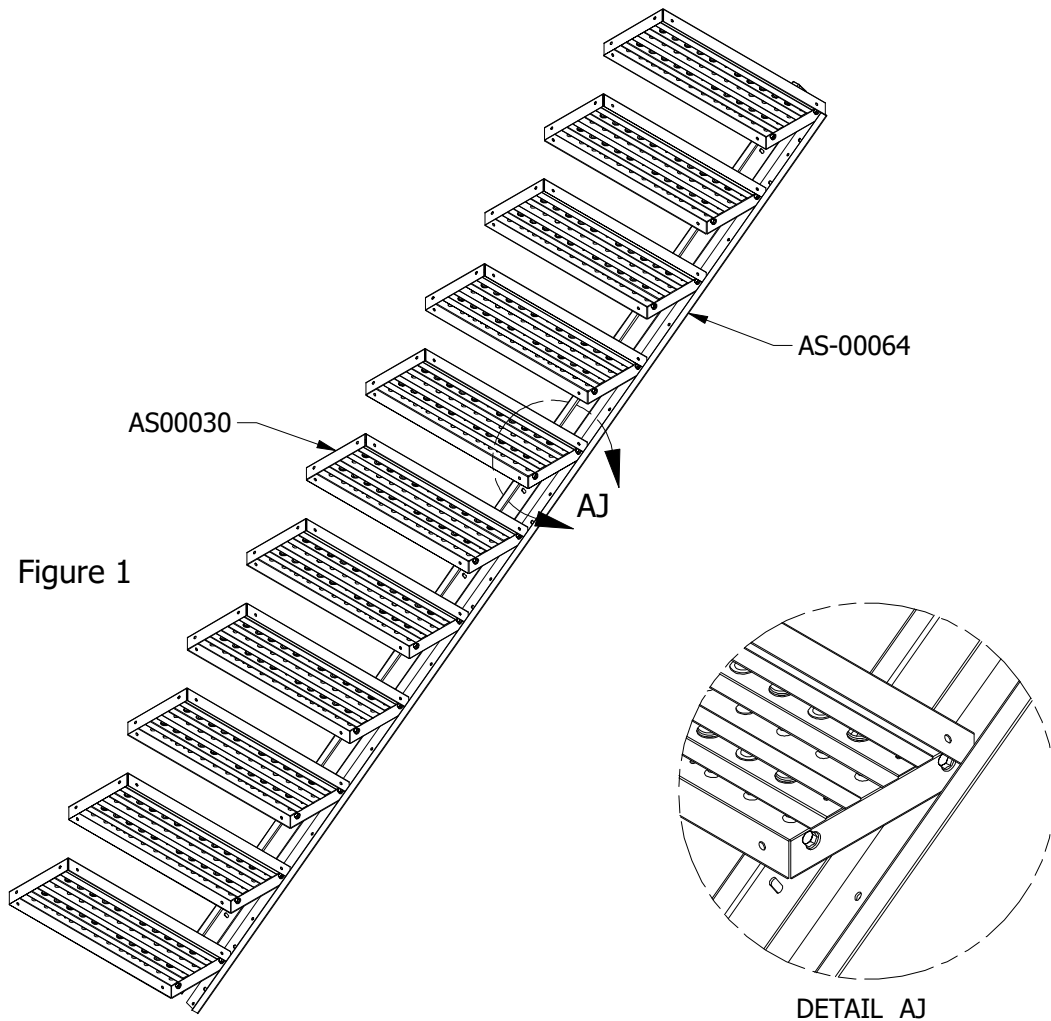

PARTS USED IN STEP 1		
PART NUMBER	DESCRIPTION	QTY
AS00030	Tread 30 x 11 Step Assembly	11
AS-00064	Angle Starter Siderail VP 11 step	2
3/8-16x1SFB	3/8"-16 x 1" Flange Bolt	22
3/8-16SFN	3/8"-16 Whiz Lock Nut	22

When this step is completed, the assembly should look like this:

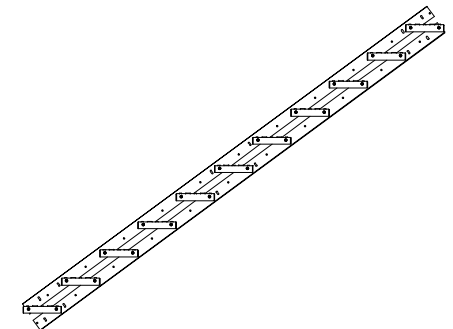

Step 2

- A. Take other side rails (AS-00064) and line the holes up with the stairs on the assembly to match the current side rails. The flange should be facing inwards, like the AS-00064 side rails in the previous step.
- B. Secure the side rail to the steps with twenty-two (22) 3/8" Flange Bolts and twenty-two (22) 3/8" Lock Nuts. The bolts should be facing outward from the side rail.

*Leave bolts loose for Step 3.

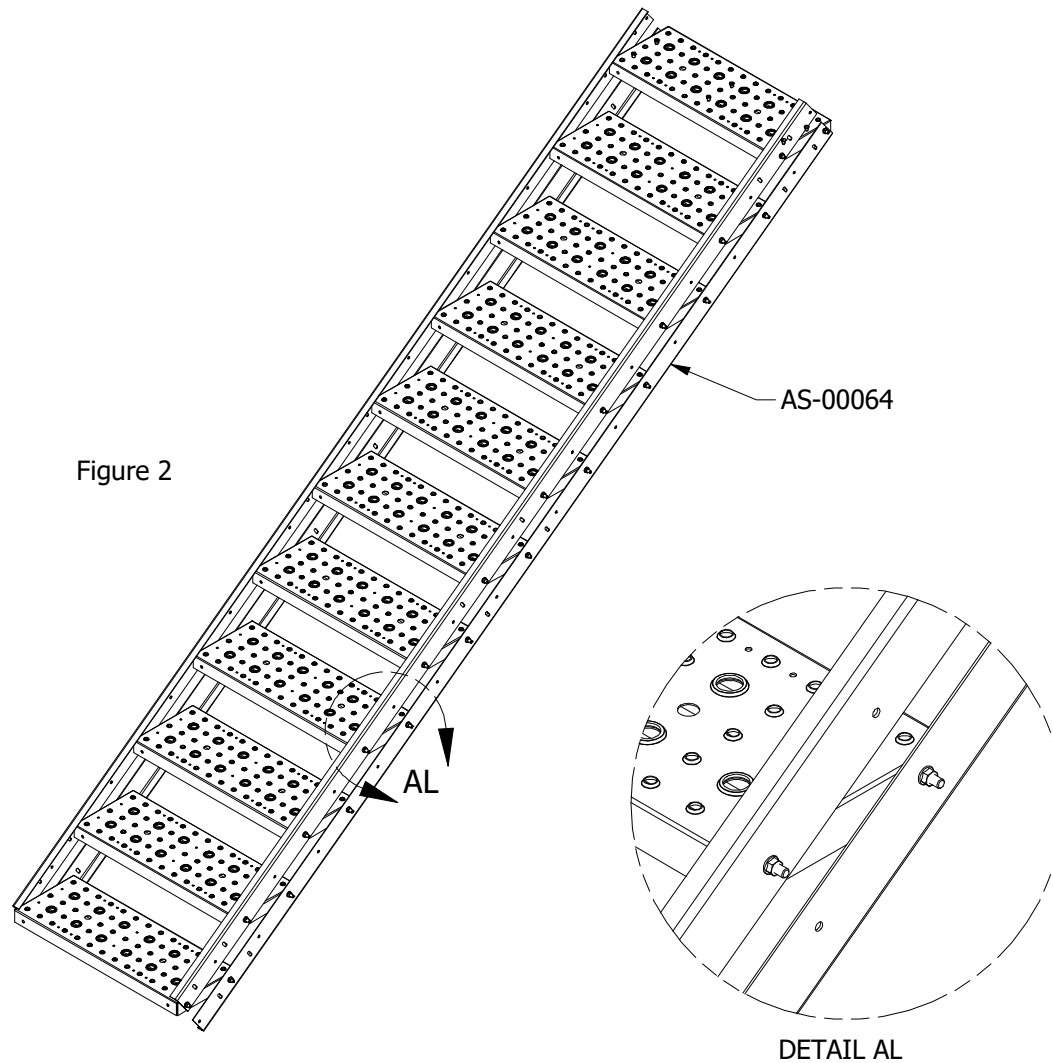

Figure 2

AS-00064

AL

DETAIL AL

PARTS USED IN STEP 2		
PART NUMBER	DESCRIPTION	QTY
AS-00064	Angle Starter Siderail VP 11 step	2
3/8-16x1SFB	3/8"-16 x 1" Flange Bolt	22
3/8-16SFN	3/8"-16 Whiz Lock Nut	22

When this step is completed, the assembly should look like this:

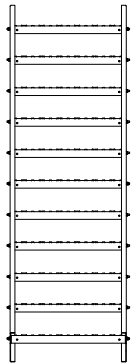

Step 3

- A. Take the six (6) AS-00033 leveling plates and place three (3) on each side of the assembly, securing them to steps 1, 6, and 11 with the existing 3/8" Flange Bolts and 3/8" Lock Nuts.
- B. On the bottom AS-00033 leveling plate on each side, secure one (1) AS-00031 anchor using two (2) 3/8" Flange Bolts and two (2) 3/8" Lock Nuts. See Figure 3, Detail AN.

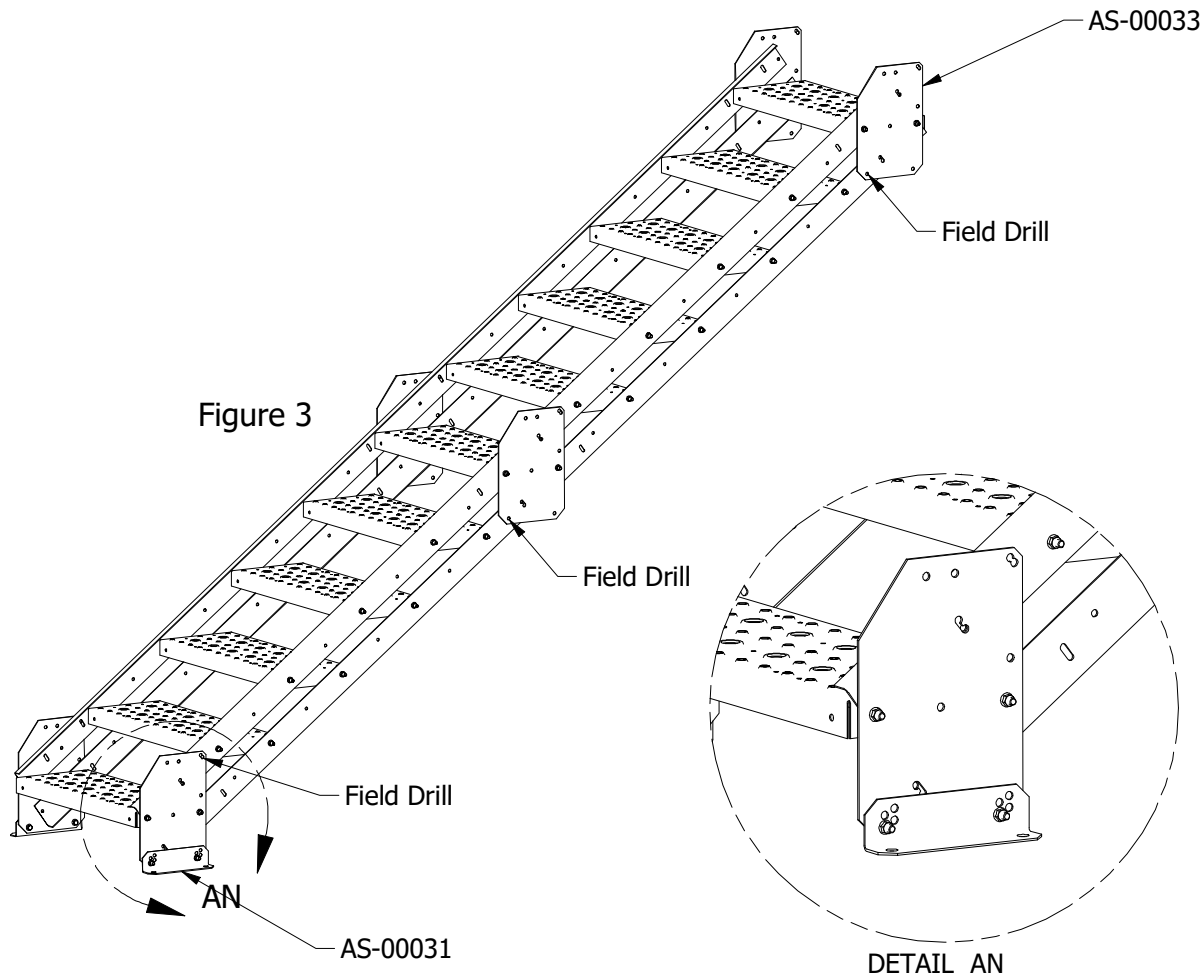

PARTS USED IN STEP 3		
PART NUMBER	DESCRIPTION	QTY
AS-00031	Angle Starter Anchor	2
AS-00033	Bracket Leveling Plate Upper	6
3/8-16xSFB	3/8"-16 x 1" Flange Bolt	4
3/8-16SFN	3/8"-16 Whiz Lock Nut	4

When this step is completed, the assembly should look like this:

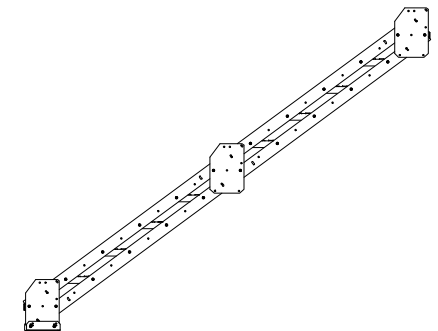

Step 4

- A. Take the six (6) AS-00032 posts and place one (1) on each AS-00064 leveling plate.
- B. On each post, line up the holes with the same hole pattern found on the AS-00064 leveling plate. See Figure 3, Detail AR.
- C. Secure each post with three (3) 3/8" Flange Bolts and three (3) 3/8" Lock Nuts. The bolts should be facing out from the assembly. See Figure 3, Detail AR.

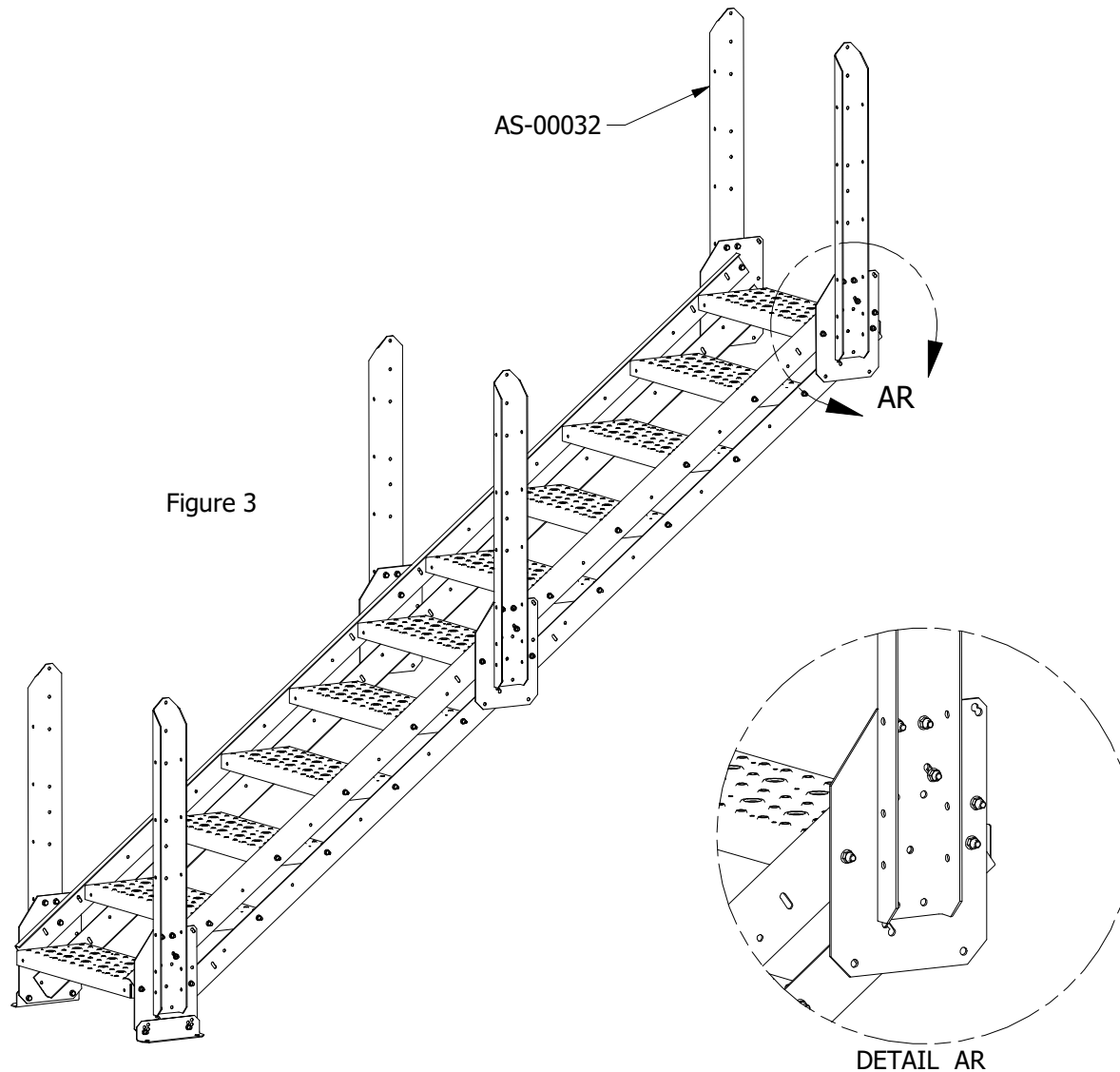

PARTS USED IN STEP 4		
PART NUMBER	DESCRIPTION	QTY
AS-00032	Channel Post Stair VP	6
3/8-16xSFB	3/8"-16 x 1" Flange Bolt	18
3/8-16SFN	3/8"-16 Whiz Lock Nut	18

When this step is completed, the assembly should look like this:

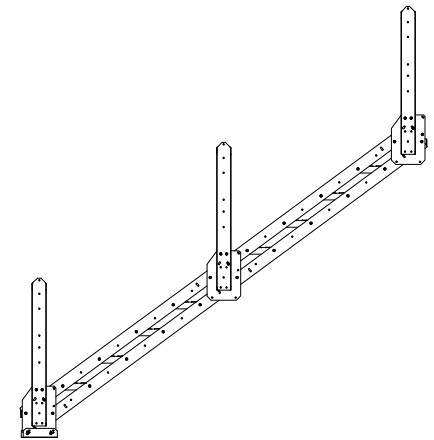

Step 5

- Take the six (6) HRC1500 clamps and twelve (12) HRC1000 clamps and arrange them as shown in Figure 5, Sections AV and AW. HRC1500 is represented in Detail AV, HRC1000 is represented in Detail AW.
- Bend open the handrail clamps and insert handrails TR1513700 and TR1013700. TR1513700 will be paired with the HRC1500 clamps, and TR1013700 will be paired with the HRC1000 clamps.
- Bend the handrail clamps back over the handrails, and secure to the AS-00032 posts using a 5/16" Flange Bolt and 5/16" Lock Nut. This step will require eighteen (18) of each. The bolts should be facing towards the outside of the stairs.
- Once the handrails have been positioned for final assembly, secure the handrails to the clamps by using a Floor Screw at each clamp.

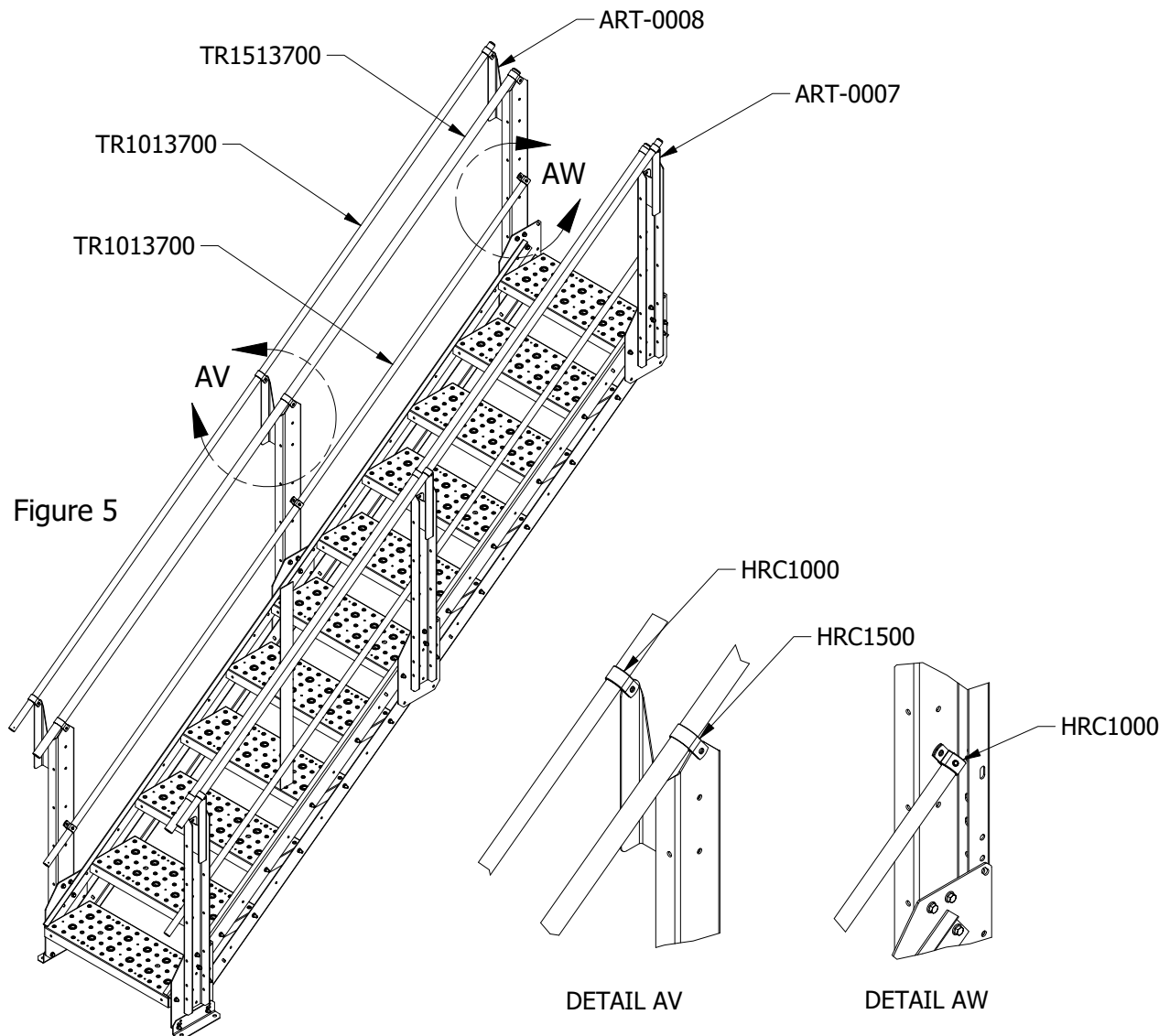

PARTS USED IN STEP 5		
PART NUMBER	DESCRIPTION	QTY
HRC1500	1.5" Handrail Clamp	6
HRC1000	1" Handrail Clamp	12
TR1513700	1.5" Top Handrail	2
TR1013700	1" Intermediate Handrail	4
ART-0007	Entry Guardrail Post Right	3
ART-0008	Entry Guardrail Post Left	3
5/16-18x3/4FB	5/16"-18 x 13/4" Flange Bolt	18
5/16-18SFN	5/16"-18 Whiz Lock Nut	18
FloorScrews	Self-Tapping Screw	18

When this step is completed,
the assembly is complete.

